

***TM 10-5411-206-24P**

TECHNICAL MANUAL

**UNIT, DIRECT SUPPORT AND GENERAL SUPPORT MAINTENANCE
REPAIR PARTS AND SPECIAL TOOLS LIST**

for

**SHELTER, ELECTRICAL EQUIPMENT
S-280B/G (NSN 5411-00-117-2868)
S-280B/G (SHIELDED) (NSN 5411-00-001-4093)**

DISTRIBUTION STATEMENT A: Approved for public release; distribution is unlimited.

* This manual supersedes S-280B/G portions of TM 11-5410-213-14P, dated April 1978.

**HEADQUARTERS, DEPARTMENT OF THE ARMY
30 SEPTEMBER 1993**

CHANGE
NO. 1

HEADQUARTERS
DEPARTMENT OF THE ARMY
WASHINGTON, D.C., 31 OCTOBER 1994

UNIT, DIRECT SUPPORT AND GENERAL SUPPORT MAINTENANCE
REPAIR PARTS AND SPECIAL TOOLS LIST
FOR
SHELTER, ELECTRICAL EQUIPMENT
S-280B/G (NSN 5411-00-117-2868)
S-280B/G (SHIELDED) (NSN 5411-00-001-4093)

DISTRIBUTION STATEMENT A: Approved for public release; distribution is unlimited.

TM 10-5411-206-24P, 30 September 1993, is changed as follows:

1. Remove and insert pages as indicated below. New or changed text material is indicated by a vertical bar in the margin. An illustration change is indicated by a miniature pointing hand.

Remove pages

I-1 through I-4
I-7 and I-8

Insert pages

I-1 through I-4
I-7 and I-8

2. Retain this sheet in front of manual for reference purposes.

By Order of the Secretary of the Army:

Official:

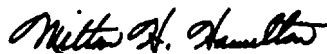

MILTON H. HAMILTON
Administrative Assistant to the
Secretary of the Army
07634

GORDON R. SULLIVAN
General, United States Army
Chief of Staff

DISTRIBUTION:

To be distributed in accordance with DA Form 12-25-E, block no. 6168, requirements for TM 10-5411-206-24P.

TECHNICAL MANUAL
 NO. 10-5411-206-24P

HEADQUARTERS
 DEPARTMENT OF THE ARMY
 WASHINGTON D.C., 30 SEPTEMBER 1993

TECHNICAL MANUAL

**Unit, Direct Support and General Support Maintenance
 Repair Parts and Special Tools List
 for
 SHELTER, ELECTRICAL EQUIPMENT
 S-280B/G (NSN 5411-00-117-2868)
 S-280B/G (SHIELDED) (NSN 5411-00-001-4093)**

Current as of 13 September 1993

REPORTING ERRORS AND RECOMMENDING IMPROVEMENTS

You can help improve this manual. If you find any mistakes or if you know of a way to improve the procedures, please let us know. Mail your letter, DA Form 2028 (Recommended Changes to Publications and Blank Forms), or DA Form 2028-2 located in the back of this manual directly to: Commander, US Army Aviation and Troop Command, ATTN: AMSAT-I-MP, 4300 Goodfellow Blvd., St. Louis, MO 63120-1798. A reply will be furnished directly to you.

DISTRIBUTION STATEMENT A: Approved for public release; distribution is unlimited.

TABLE OF CONTENTS

		PAGE	ILLUS/ FIGURE
Section I.	INTRODUCTION	I	
Section II.	REPAIR PARTS LIST	1-1	
Group 00	Shelter, Electrical Equipment		
	Drip Mold, Data Plates and Base Hardware	1-1	1
Group 01	Door Brace Assembly		
	Door Brace Assembly	2-1	2
Group 02	Door Assembly		
	Door Assembly	3-1	3
	Emergency Exit Panel Assembly	4-1	4
	Door Handles, Locks and Latches	5-1	5
Group 03	Towing Eye Assembly		
	Towing Eye Assembly	6-1	6
Group 04	Lifting Eye Assembly		
	Lifting Eye Assembly	7-1	7
Group 05	Steps, Hand Holds and Drain Plug		
	Steps, Hand Holds and Drain Plug	8-1	8
Group 06	RFI Components		
	RFI Components	9-1	9
Group 07	Skid Assembly and Mounting Brackets		
	Skid Assembly and Mounting Brackets	10-1	10
Section III.	SPECIAL TOOLS LIST (Not Applicable)		

* This manual supersedes S-280B/G portions of TM 11-5410-213-14P, dated April 1978.

Section IV.	CROSS REFERENCE INDEXES	
	National Stock Number Index	I-1
	Part Number Index	I-2
	Figure and Item Number Index	I-6

UNIT, DIRECT SUPPORT AND GENERAL SUPPORT MAINTENANCE REPAIR PARTS AND SPECIAL TOOLS LIST

Section I. INTRODUCTION

1. SCOPE. This RPSTL lists and authorizes spares and repair parts; special tools; special test, measurement, and diagnostic equipment (TMDE); and other special support equipment required for performance of unit, direct support and general support maintenance of the Shelter, Electrical Equipment, S-280B/G and S-280B/G (Shielded). It authorizes the requisitioning, issue, and disposition of spares, repair parts and special tools as indicated by the source, maintenance and recoverability (SMR) codes.

2. GENERAL. In addition to this section, Introduction, this Repair Parts and Special Tools List is divided into the following sections:

a. Section II. Repair Parts List. List. A list of spares and repair parts authorized by this RPSTL for use in the performance of maintenance. This list also includes parts which must be removed for replacement of the authorized parts. Parts lists are composed of functional groups in ascending alphanumeric sequence, with the parts in each group listed in ascending figure and item number sequence. Bulk materials are listed in item name sequence. Items are shown in the associated illustration(s)/figure(s).

b. Section III. Special Tools List. A list of special tools, special TMDE, and other special support equipment authorized by this RPSTL (as indicated by Basis of Issue (BOI) information in DESCRIPTION AND USABLE ON CODE column) for the performance of maintenance.

c. Section IV. Cross-Reference Index. A list, in National Item Identification Number (NIIN) sequence, of all National stock numbered items appearing in the listing, followed by a list in alphanumeric sequence of all part numbers appearing in the listings. National stock numbers and part numbers are cross referenced to each illustration figure and item number appearance. The figure and item number index lists figure and item numbers in alphanumeric sequence and cross references NSN, CAGEC and part number.

3. EXPLANATION OF COLUMNS (SECTIONS II AND III).

a. ITEM NO. (Column (1)). Indicates the number used to identify items called out in the illustration.

b. SMR Code (Column (2)). The Source, Maintenance, and Recoverability (SMR) code is a 5-position code containing supply/requisitioning information, maintenance category authorization criteria, and disposition instruction, as shown in the following breakout:

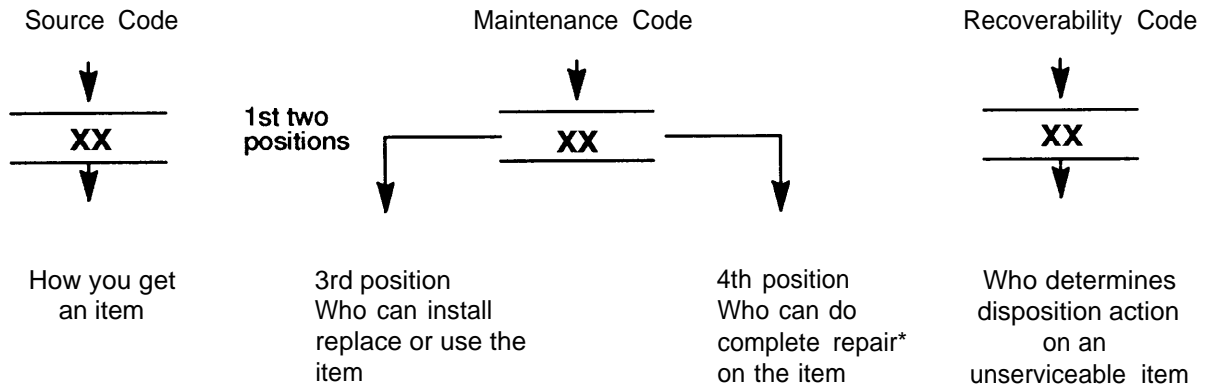

* Complete Repair: Maintenance capacity, capability, and authority to perform all corrective maintenance tasks of the "Repair" function in a use/user environment in order to restore serviceability to a failed item.

(1) Source Code. The source code tells you how to get an item needed for maintenance, repair, or overhaul of an end item/equipment. Explanations of source codes follows:

Source Code	Explanation
PA PB PC**	<p>Stocked items; use the applicable NSN to request/requisition items with these source codes. They are authorized to the category indicated by the code entered in the 3rd position of the SMR code.</p> <p>**NOTE: Items coded PC are subject to deterioration.</p>
PD PE PF PG	
KD KF KB	<p>Items with these codes are not to be requested/requisitioned individually. They are part of a kit which is authorized to the maintenance category indicated in the 3rd position of the SMR code. The complete kit must be requisitioned and applied.</p>
MO - (Made at Unit/AVUM Level) MF - (Made at DS/AVUM Level) MH - (Made at GS Level) ML - (Made at Specialized Repair Activity (SRA)) MD - (Made at Depot)	<p>Items with these codes are not to be requested/requisitioned individually. They must be made from bulk material which is identified by the part number in the DESCRIPTION and USABLE ON CODE (UOC) column and listed in the Bulk Material group of the repair parts list in this RPSTL. If the item is authorized to you by the 3rd position code of the SMR code, but the source code indicates it is made at a higher level, order the item from the higher level of maintenance.</p>
AO - (Assembled by Unit/AVUM Level) AF - (Assembled by DS/AVIM Level) AH - (Assembled by GS Category) AL - (Assembled by SRA) AD - (Assembled by Depot)	<p>Items with these codes are not to be requested/requisitioned individually. The parts that make up the assembled item must be requisitioned or fabricated and assembled at the level of maintenance indicated by the source code. If the 3rd position code of the SMR code authorizes you to replace the item, but the source code indicates the items are assembled at a higher level, order the item from the higher level of maintenance.</p>
XA -	Do not requisition "XA"-coded item. Order its next higher assembly. (Refer to the NOTE below.)
XB -	If an "XB" item is not available from salvage, order it using the CAGEC and part number given.
XC -	Installation drawing, diagram, instruction sheet, field service drawing, that is identified manufacturer's part number.
XD -	Item is not stocked. Order an "XD"-coded item through normal supply channels using the CAGEC and part number given, if no NSN is available.

NOTE

Cannibalization or controlled exchange, when authorized, may be used as a source of supply for items with the above source codes, except for those source coded "XA" or those aircraft support items restricted by requirements of AR 750-1.

(2) Maintenance Code. Maintenance codes tell you the level(s) of maintenance authorized to USE and REPAIR support items. The maintenance codes are entered in the third and fourth positions of the SMR code as follows:

(a) The maintenance code entered in the third position tells you the lowest maintenance level authorized to remove, replace, and use an item. The maintenance code entered in the third position will indicate authorization to the following levels of maintenance.

Maintenance

Code	Application/Explanation
C-	Crew or operator maintenance done within unit/AVUM maintenance.
O-	Unit level/AVUM maintenance can remove, replace, and use the item.
F-	Direct support/AVIM maintenance can remove, replace, and use the item.
H-	General support maintenance can remove, replace, and use the item.
L-	Specialized repair activity can remove, replace, and use the item.
D-	Depot can remove, replace, and use the item.

(b) The maintenance code entered in the fourth position tells whether or not the item is to be repaired and identifies the lowest maintenance level with the capability to do complete repair (i.e., perform all authorized repair functions.)

NOTE

Some limited repair may be done on an item at a lower level of maintenance, if authorized by the Maintenance Allocation Chart and SMR codes.

Maintenance

Code	Application/Explanation
O-	Unit/AVUM is the lowest level that can do complete repair of the item.
F-	Direct support/AVIM is the lowest level that can do complete repair of the item.
H-	General Support is the lowest level that can do complete repair of the item.
L-	Specialized repair activity is the lowest level that can do complete repair of the item.
D-	Depot is the lowest level that can do complete repair of the item.
Z-	Nonreparable. No repair is authorized.
B-	No repair is authorized. No parts or special tools are authorized for the maintenance of a "B" coded item. However, the item may be reconditioned by adjusting, lubricating, etc., at the user level.

(3) Recoverability Code. Recoverability codes are assigned to items to indicate the disposition action on unserviceable items. The recoverability code is entered in the fifth position of the SMR Code as follows:

Recoverability Codes

Application/Explanation

- Z- Nonreparable item. When unserviceable, condemn and dispose of the item at the level of maintenance shown in 3d position of SMR Code.
- O- Reparable item. When not economically reparable, condemn and dispose of the item at unit or AVUM level.
- F- Reparable item. When uneconomically reparable, condemn and dispose of the item at the direct support or AVIM level.
- H- Reparable item. When uneconomically reparable, condemn and dispose of the item at the general support level.
- D- Reparable item. When beyond lower level repair capability, return to depot. Condemnation and disposal of item not authorized below depot level.
- L- Reparable item. Condemnation and disposal not authorized below specialized repair activity (SRA).
- A- Item requires special handling or condemnation procedures because of specific reasons (e.g., precious metal content, high dollar value, critical material, or hazardous material). Refer to appropriate manuals/directives for specific instructions.

c. CAGEC (Column (3)). The Commercial and Government Entity Code (CAGEC) is a 5-digit numeric code which is used to identify the manufacturer, distributor, or Government agency/activity that supplies the item.

d. PART NUMBER (Column (4)). Indicates the primary number used by the manufacturer, (individual, company, firm, corporation, or Government activity), which controls the design and characteristics of the item by means of its engineering drawings, specifications, standards, and inspection requirements to identify an item or range of items.

NOTE

When you use an NSN to requisition an item, the item you receive may have a different part number from the number listed.

e. DESCRIPTION AND USABLE ON CODE (UOC) (Column (5)). This column includes the following information:

(1) The Federal item name and, when required, a minimum description to identify the item.

(2) Part numbers of bulk materials are referenced in this column in the line entry to be manufactured/fabricated.

(3) The statement "END OF FIGURE" appears just below the last item description in Column (5) for a given figure in both Section II and Section III.

f. QTY (Column (6)). The QTY (quantity per figure) column indicates the quantity of the item used in the breakout shown on the illustration/figure, which is prepared for a functional group, subfunctional group, or an assembly. A "V" appearing in this column instead of a quantity indicates that the quantity is variable and may vary from application to application.

4. EXPLANATION OF INDEX FORMAT AND COLUMNS (SECTION IV).

a. NATIONAL STOCK NUMBER (NSN) INDEX.

(1) STOCK NUMBER Column. This column lists the NSN in national item identification number (NIIN) sequence. The NIIN consists of the last nine digits of the NSN, i.e.

NSN
5305-01-574-1467
NIIN

When using this column to locate an item, ignore the first four digits of the NSN. Use the complete NSN (13 digits) when requisitioning items by stock number.

(2) FIG. Column. This column lists the number of the figure where the item is identified/located. The figures are in numerical order in Section II and Section III.

(3) ITEM Column. The item number identifies the item associated with the figure listed in the adjacent FIG. column. This item is also identified by the NSN listed on the same line.

b. PART NUMBER INDEX. Part numbers in this index are listed by part number in ascending alphanumeric sequence (i e., vertical arrangement of letter and number combination which places the first letter or digit of each group in order A through Z, followed by the numbers 0 through 9, and each following letter or digit in like order).

(1) CAGEC Column. The Commercial and Government Entity Code (CAGEC) is a 5-digit numeric code used to identify the manufacturer, distributor, or Government agency/activity that supplies the item.

(2) PART NUMBER Column. Indicates the primary number used by the manufacturer (individual, firm, corporation, or Government activity), which controls the design and characteristics of the item by means of its engineering drawings, specifications, standards, and inspection requirements to identify an item or range of items.

(3) STOCK NUMBER Column. This column lists the NSN for the associated part number and manufacturer identified in the PART NUMBER and CAGEC columns to the left.

(4) FIG. Column. This column lists the number of the figure where the item is identified/located in Section II and Section III.

(5) ITEM Column. The item number is that number assigned to the item as it appears in the figure referenced in adjacent figure number column.

c. FIGURE AND ITEM NUMBER INDEX.

(1) FIG. Column. This column lists the number of the figure where the item is identified/located in Section II and Section III.

(2) ITEM Column. The item number is that number assigned to the item as it appears in the figure referenced in the adjacent figure number column.

(3) STOCK NUMBER Column. This column lists the NSN for the item.

(4) CAGEC Column. The Commercial and Government Entity Code (CAGEC) is a 5-digit numeric code used to identify the manufacturer, distributor, or Government agency/activity that supplies the item.

(5) PART NUMBER Column. Indicates the primary number used by the manufacturer (individual, firm, corporation, or Government activity), which controls the design and characteristics of the item by means of its engineering drawings, specifications, standards, and inspection requirements to identify an item or range of items.

5. SPECIAL INFORMATION.

a. USABLE ON CODE The usable on code appears in the lower left corner of the Description Column heading. Usable on codes are shown as "UOC:.." in the Description Column (justified left) on the last line of the applicable item description/nomenclature. Uncoded items are applicable to all models. Identification of the usable on codes used in this RPSTL are:

<u>Code</u>	<u>Used On</u>
EBR	Model S-280B/G
EKV	Model S-280BC (Shielded)

b. FABRICATION INSTRUCTIONS. Bulk materials required to manufacture items are listed in the Bulk Material Functional Group of this RPSTL. Part numbers for bulk materials are also referenced in the description column of the line entry for the item to be manufactured/fabricated. Detailed fabrication instructions for items source coded to be manufactured or fabricated are found in TM 10-5411-206-14.

c. INDEX NUMBERS. Items which have the word BULK in the figure column will have an index number shown in the item number column. This index number is a cross-reference between the National Stock Number/Part Number Index and the bulk material list in Section II.

d. ASSOCIATED PUBLICATIONS. The publications listed below pertain to the Shelter, Electrical Equipment, S-280B/G and S-280B/G (Shielded) and their components.

Publication

TM 10-5411-206-14

Short Title

Operator, Unit, Direct Support and General
Support Maintenance Manual.

6. **HOW TO LOCATE REPAIR PARTS.**

a. **When National Stock Numbers or Part Numbers are NOT Known.**

(1) **First.** Using the table of contents, determine the assembly or subassembly group to which the item belongs. This is necessary since figures are prepared for assembly groups and subassembly groups, and listings are divided into the same groups.

(2) **Second.** Find the figure covering the assembly group or subassembly group to which the item belongs.

(3) **Third.** Identify the item on the figure and use the Figure and Item Number Index to find the NSN.

b. **When National Stock Number or Part Number is Known.**

(1) **First.** Using the of National Stock Number and Part Number Indexes find the pertinent National Stock Number or Part Number. The NSN index is in National Item Identification Number (NIIN) sequence (see paragraph 4a.). The part numbers in the Part Number index are listed in ascending alphanumeric sequence (see paragraph 4.b.). Both indexes cross-reference you to the illustration/figure and item number of the item you are looking for.

(2) **Second.** Turn to the figure and item number, verify that the item is the one you are looking for, then locate the item number in the repair parts list for the figure.

7. **ABBREVIATIONS.** Abbreviations used in this manual are listed in MIL-STD-12.

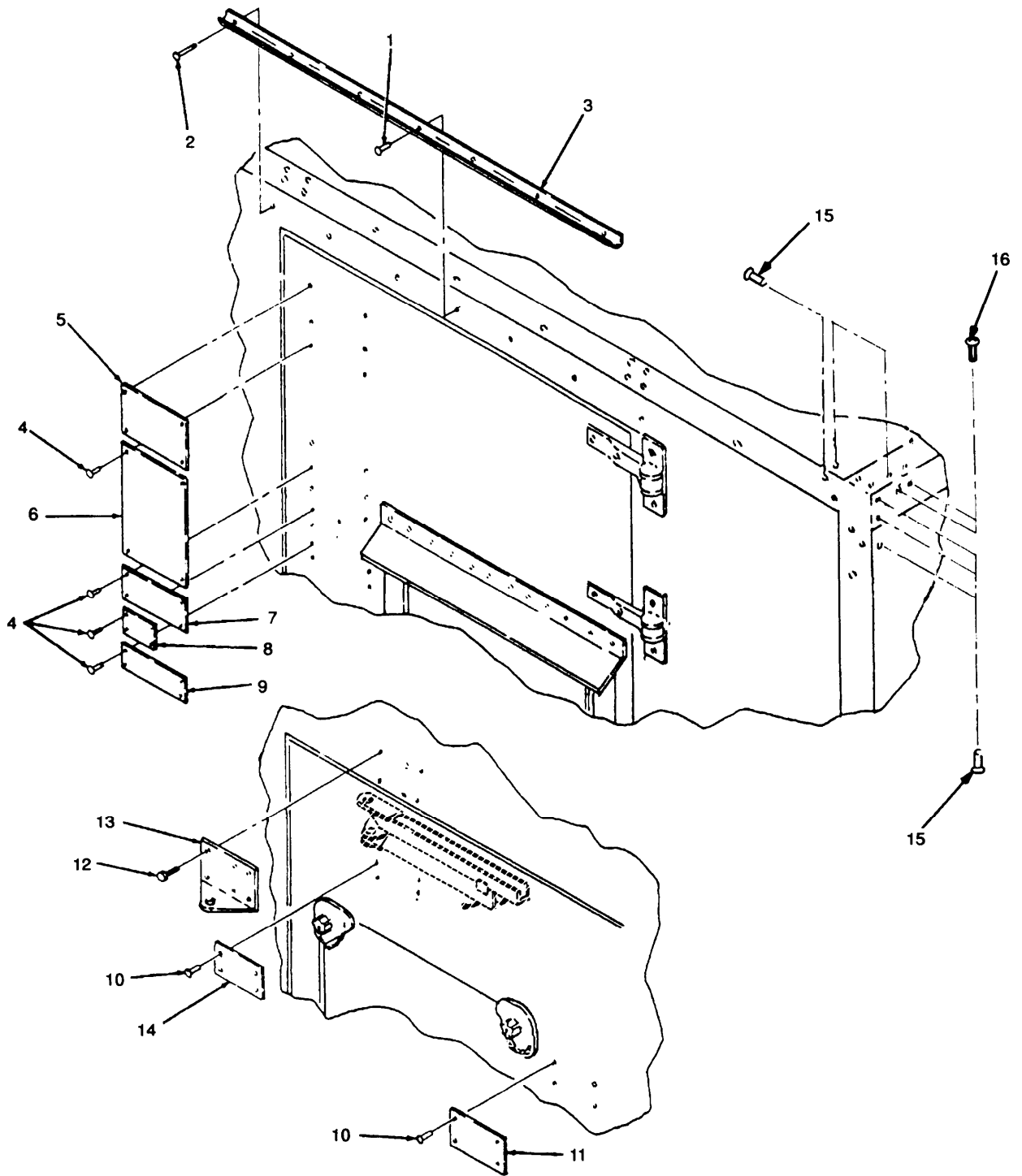

Figure 1. Drip Mold, Data Plates and Base Hardware (Sheet 1 of 2).

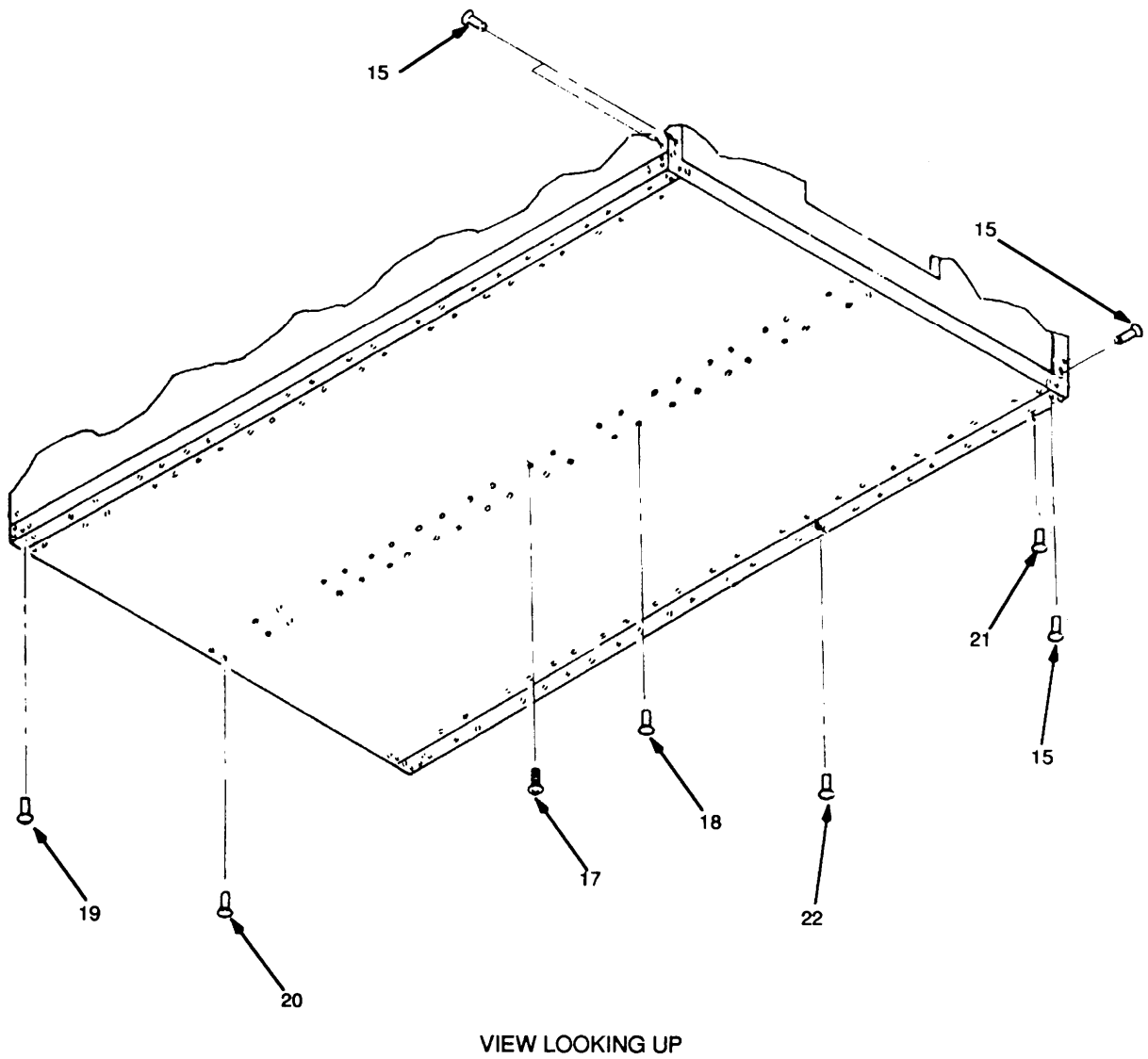

Figure 1. Drip Mold, Data Plates and Base Hardware (Sheet 2 of 2).

(1) ITEM NO	(2) SMR CODE	(3) CAGEC	(4) PART NUMBER	(5) DESCRIPTION AND USABLE ON CODES (UOC)	(6) QTY
GROUP 00 SHELTER, ELECTRICAL EQUIPMENT					
FIG. 1 DRIP MOLD, DATA PLATES AND BASE HARDWARE					
1	PAHZZ	07707	AD45H	RIVET,BLIND	8
2	PAHZZ	81349	M24243/6-A404H	RIVET,BLIND	4
3	XBFZZ	80063	SM-B-165303	DRIP MOLD, DOOR	1
4	PAHZZ	96906	MS20600AD4W2	RIVET,BLIND	36
5	XBHZZ	80063	SM-B-555555	PLATE,DATA,AIRCRAFT	1
6	XBHZZ	80063	SM-C-165466	PLATE	1
7	XBHZZ	80063	SM-B-165463	NAME,PLATE	1
8	XBHZZ	80063	SM-B-340031	PLATE,AIRBORNE	1
9	XBHZZ	80063	SM-B-317089	PLATE, PAINT INSTR	1
10	PAHZZ	96906	MS20600AD4W2	RIVET,BLIND	8
11	XBHZZ	81337	SM-B-615256	PLATE,SECEXIT,DATA	1
12	PAHZZ	88044	AN101011	BOLT,MACHINE	6
13	PAHZZ	81337	SCC200135	BRACKET,ANGLE	1
14	XBHZZ	80063	SM-C-564811	PLATE,INSTRUCTION	1
15	XBHZZ	25472	S37B285	NUT,PLAIN,BLIND RIV	72
16	PAHZZ	96906	MS51957-81	SCREW,MACHINE	8
17	PAHZZ	96906	MS35191-273	SCREW,MACHINE	48
18	PAFZZ	25472	S10B130	NUT,PLAIN,BLIND RIV	8
19	XBFZZ	03481	S31B275	NUT,PLAIN,BLIND RIV	8
20	PAHZZ	83187	S31B500	NUT,PLAIN,BLIND RIV	4
21	PAHZZ	03481	S25B211	NUT,PLAIN,BLIND RIV	88
22	PAHZZ	03481	S10B216	NUT,PLAIN,BLIND RIV	16

END OF FIGURE

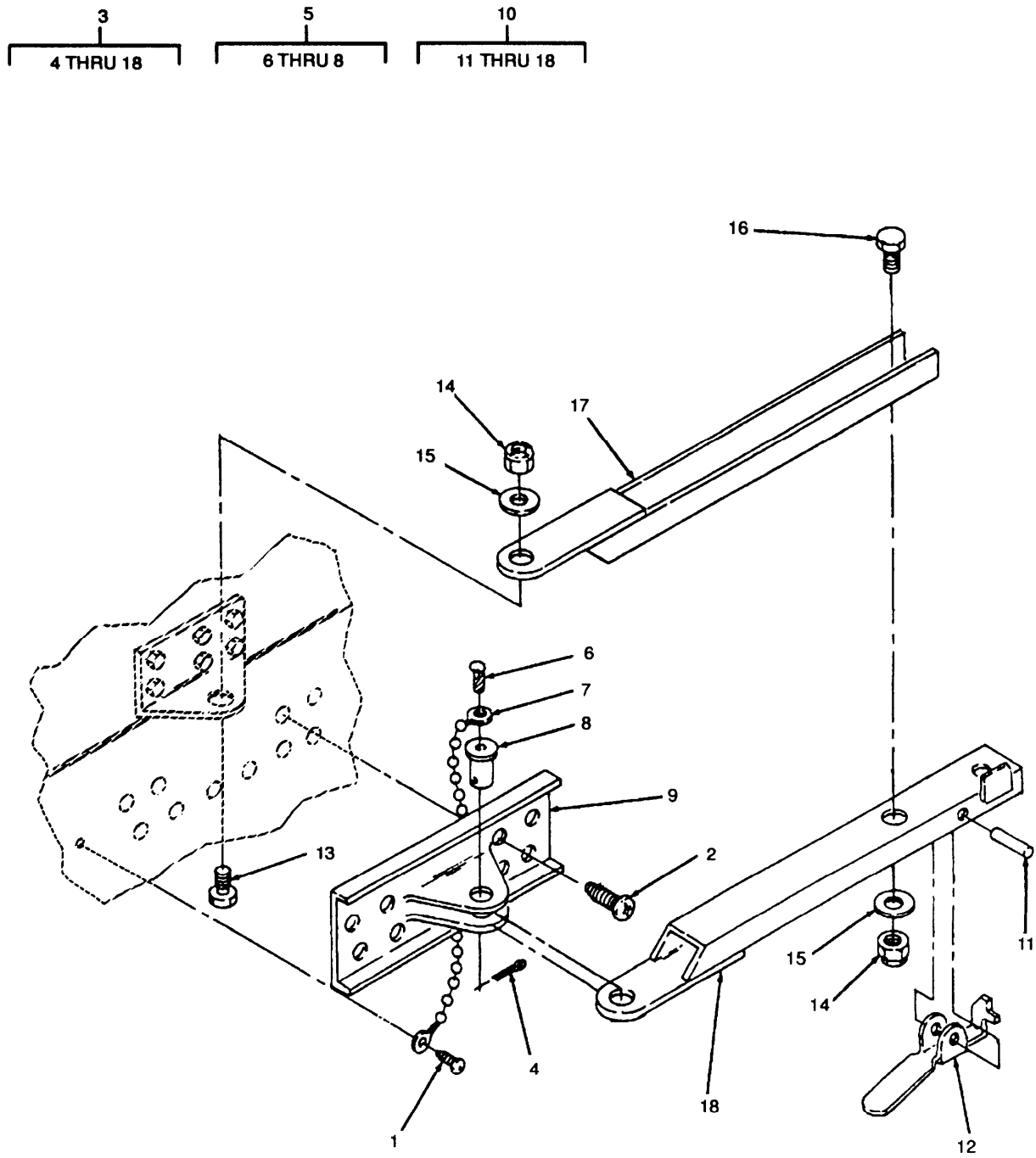

Figure 2. Door Brace Assembly.

(1) ITEM NO	(2) SMR CODE	(3) CAGEC	(4) PART NUMBER	(5) DESCRIPTION AND USABLE ON CODES (UOC)	(6) QTY
GROUP 01 DOOR BRACE ASSEMBLY					
FIG. 2 DOOR BRACE ASSEMBLY					
1	PAFZZ	96906	MS35493-53	SCREW,WOOD	1
2	PAHZZ	96906	MS24617-54	SCREW,TAPPING	10
3	PAFZZ	81337	SC-D-595548	DOOR BRACE ASSEMBLY	1
4	PAFZZ	96906	MS24665-285	PIN,COTTER	1
5	PAHZZ	80063	SMB340027	PIN AND CHAIN ASSY	1
6	PAHZZ	96906	MS21318-46	SCREW,DRIVE	1
7	XBHZZ	70892	13ANOFFSET	FASTENER,BEAD CHAIN	2
8	XAHZZ	80063	SC-B-781199	TAB	1
9	XAFZZ	80063	SM-C-340028	BRACKET,DOOR STOP	1
10	PAFZZ	80063	SC-D-595078	DOOR BRACE ASSEMBLY	1
11	XBHZZ	96906	MS5171536	PIN, ROLL	1
12	XDHZZ	96906	MS24655-281	SWITCH,TOGGLE	1
13	PAHZZ	80063	SMB564727-2	BOLT,SHOULDER	1
14	XBHZZ	96906	SC-D-595078-1	NUT, HEX LOCK	2
15	PAHZZ	96906	MS27183-14	WASHER,FLAT	2
16	PAFZZ	80063	SMB564727-1	BOLT,SHOULDER	1
17	PAHZZ	80063	SC-C-200158	BRACE ASSEMBLY UPPER	1
18	PAHZZ	80063	SC-C-200157	BRACE LOWER	1

END OF FIGURE

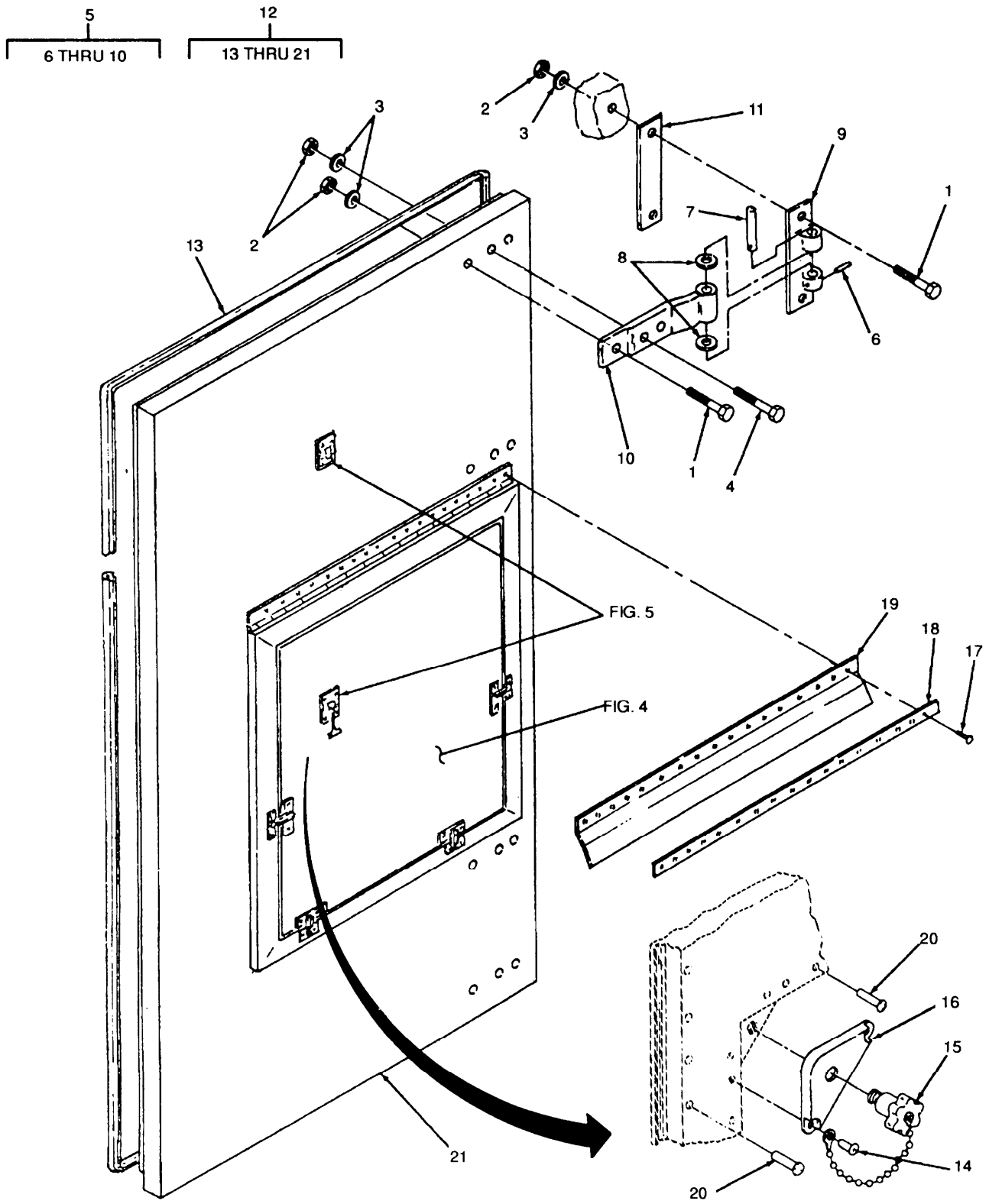

Figure 3. Door Assembly.

(1) ITEM NO	(2) SMR CODE	(3) CAGEC CAGEC	(4) PART NUMBER	(5) DESCRIPTION AND USABLE ON CODES (UOC)	(6) QTY
GROUP 02 DOOR ASSEMBLY					
FIG. 3 DOOR ASSEMBLY					
1	PAHZZ	88044	AN5C26A	BOLT,MACHINE	12
2	PAHZZ	96906	MS21042-5	NUT,SELF-LOCKING,EX	20
3	PAHZZ	96906	MS15795-812	WASHER,FLAT	20
4	PAFZZ	88044	AN5C25A	BOLT,MACHINE	1
5	PAHZZ	80063	SMC317057	HINGE,SPECIAL	1
6	XAHZZ	96906	MS16562-237	.PIN,SPRING	1
7	XAHZZ	80063	SM-B-508785	.PIN, HINGE	1
8	XAHZZ	80063	SM-B-317129	.WASHER, HINGE	2
9	XAHZZ	80063	SM-C-508784	.BUTTPLATE,HINGE	1
10	XAHZZ	80063	SM-C-508783	.BODY, HINGE	1
11	XAFZZ	80063	SM-B-162197	SHIM	4
12	XBFHH	80063	SM-D-450461	DOOR ASSEMBLY	1
13	PAHZZ	80063	SMC564839-96IN	.GASKET	1
14	PAHZZ	96906	MS21318-46	.SCREW,DRIVE	1
15	XBHZZ	80063	SM-C-615263	.KNOB, CASTING INCLUDES ATTACHING CHAIN	1
16	XBHZZ	80063	SM-C-450443	.RETAINER, AIR INLE	4
17	PAHZZ	80205	NAS1398D6A3	.RIVET,BLIND	17
18	XBHZZ	80063	SM-B-450465	.STRIP,DRIP CAP	1
19	PAHZZ	80063	SM-B-555572-6	.RUBBER STRIP	1
20	PAHZZ	07707	AD66H	.RIVET,BLIND	36
21	XBFHH	81337	SM-D-508738	.PANEL ASSY, DOOR	1

END OF FIGURE

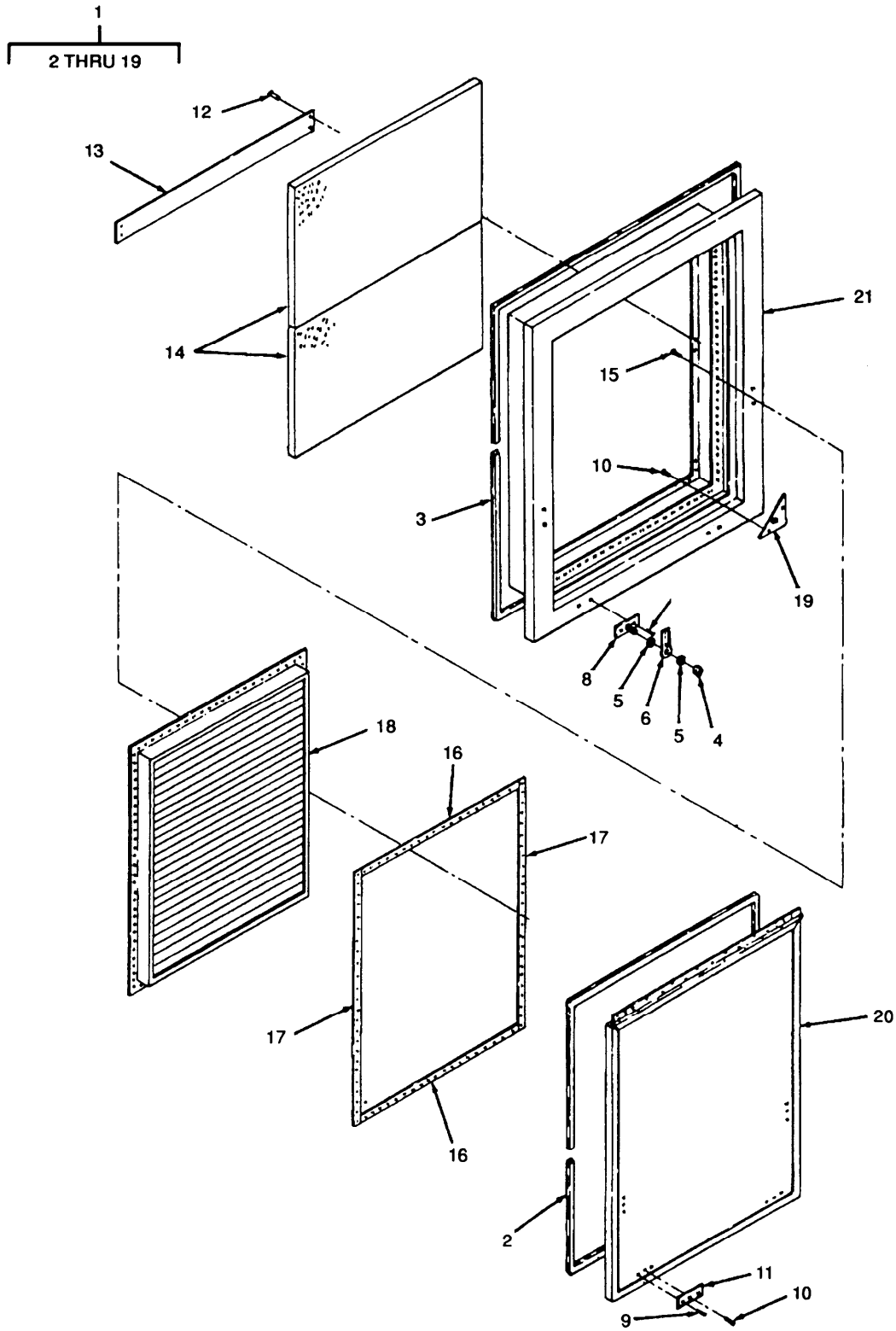

Figure 4. Emergency Exit Panel Assembly.

(1) ITEM NO	(2) SMR CODE	(3) CAGEC	(4) PART NUMBER	(5) DESCRIPTION AND USABLE ON CODES (UOC)	(6) QTY
GROUP 02 DOOR ASSEMBLY					
FIG. 4 EMERGENCY EXIT PANEL ASSEMBLY					
1	XDHHZ	80063	SM-D-450462	.PANEL ASSY	1
2	PAHZZ	80063	SMC564839-96IN	..GASKET	1
3	XDHZZ	80063	SM-C-564839-106I N	..GASKET	1
4	XDHZZ	72962	2INTU040	..NUT,PLAIN,HEXAGON	4
5	PAOZZ	80205	NAS1515H4L	..WASHER,FLAT	4
6	XDHZZ	80063	SM-B-450447	..LATCH,RIM	4
7	PAOZZ	80205	NAS1739E4-3	..RIVET,BLIND	8
8	PAOZZ	81337	SM-B-450448	..SPACER,PLATE	4
9	PAOZZ	80205	NAS1398D4-4	..RIVET,BLIND	8
10	PAOZZ	80205	NAS1399D4-4	..RIVET,BLIND	4
11	XDHZZ	80063	SC-B-595081	..STRIKE	4
12	PAOZZ	80205	NAS1398D4-3	..RIVET,BLIND	4
13	XDHZZ	80205	NAS1398D4-3	..RIVET,BLIND	1
14	XDOZZ	80063	SM-C-450466	..PLASTIC SHEET	2
15	XDHZZ	80063	SM-D-450462-10	..SCREW,MACHINE	92
16	XAHZZ	80063	SM-C-615262-1	..STRIP, LOUVER	2
17	XAHZZ	80063	SM-C-615262-2	..STRIP, LOUVER	2
18	XDHZZ	80063	SM-D-615264	..INTAKE,LOUVER	1
19	XAHZZ	80063	SM-B-450435	..CORNER GUSSET	4
20	XBHZZ	80063	SM-D-450462	.PANEL ASSY, EMERG.-	1
21	XBHZZ	80063	SM-C-508745	.FRAME ASSY INTAKE, OPENING	1

END OF FIGURE

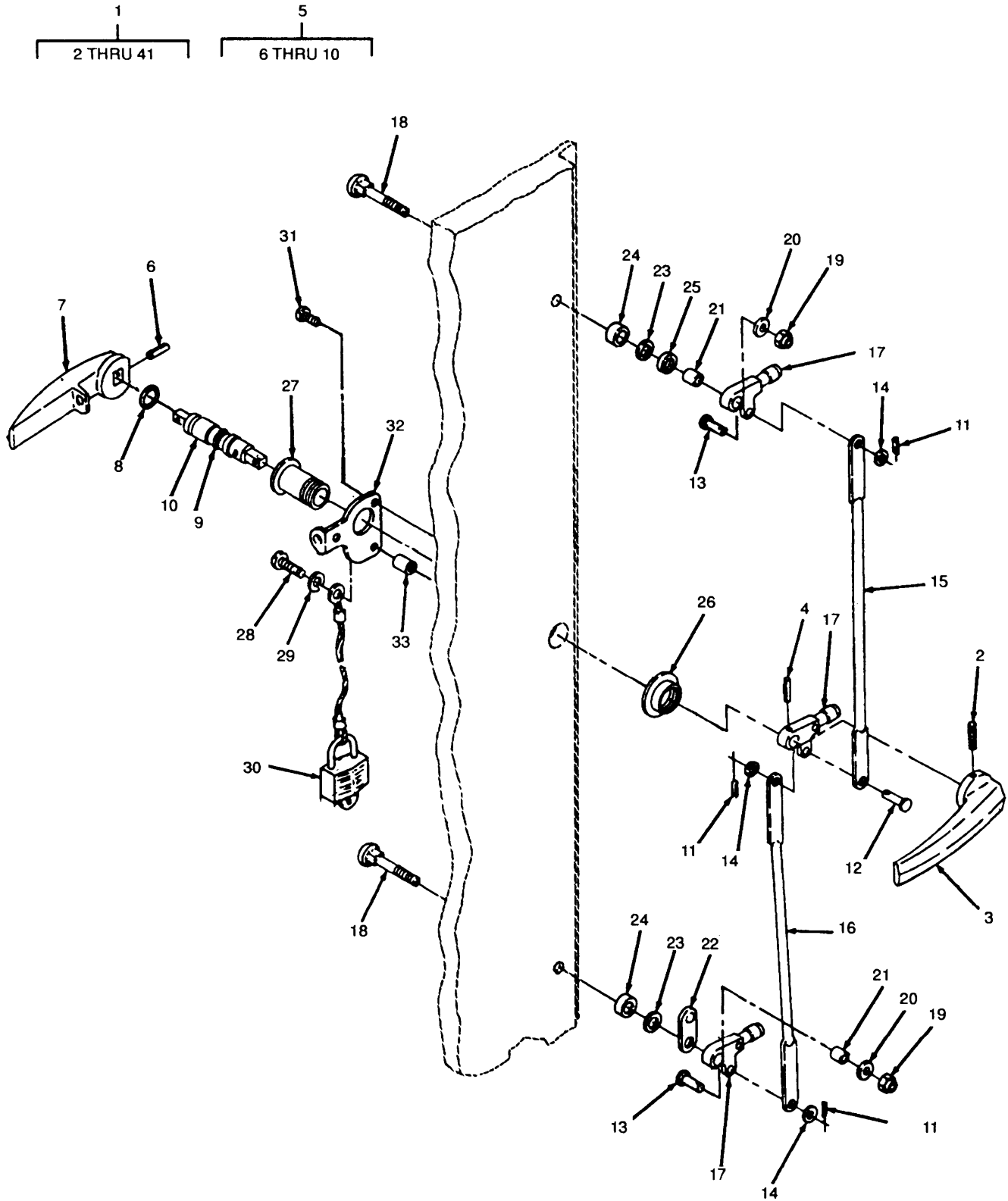

Figure 5. Door Handles, Locks and Latches (Sheet 1 of 3).

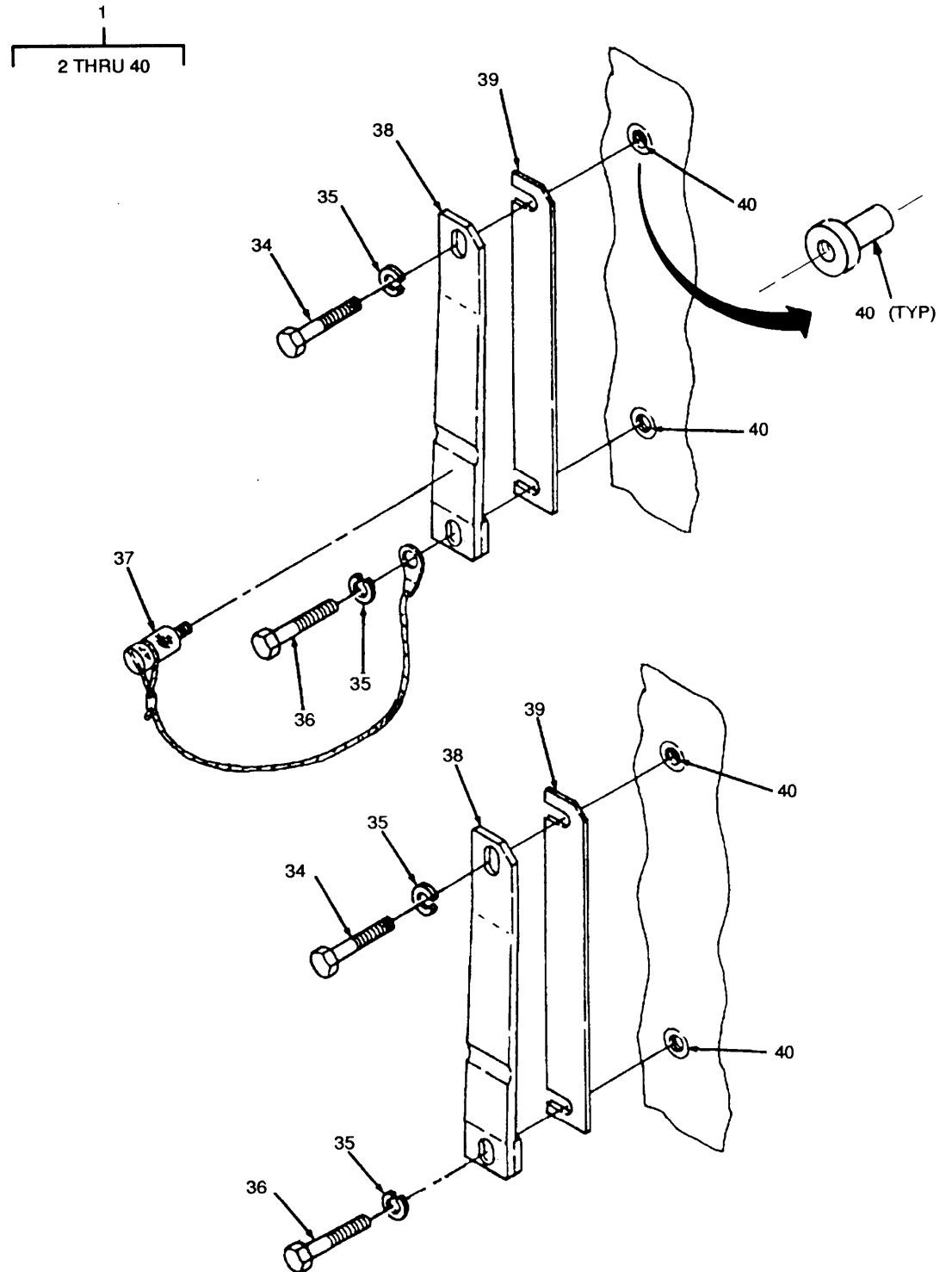

Figure 5. Door Handles, Lock and Latches (Sheet 2 of 3).

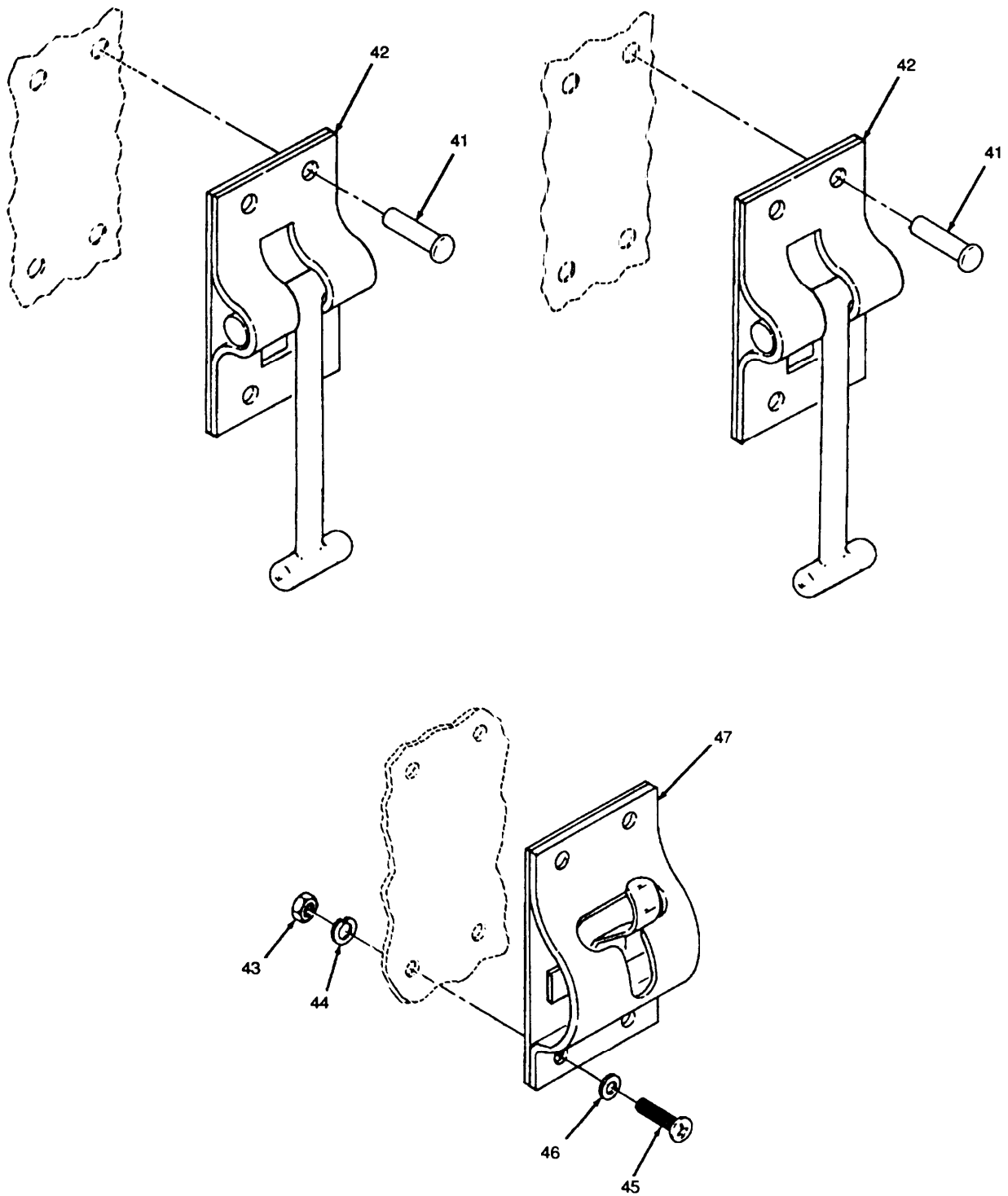

Figure 5. Door Handles, Locks and Latches (Sheet 3 of 3).

(1) ITEM NO	(2) SMR CODE	(3) CAGEC	(4) PART NUMBER	(5) DESCRIPTION AND USABLE ON CODES (UOC)	(6) QTY
GROUP 02 DOOR ASSEMBLY					
FIG. 5 DOOR HANDLES, LOCKS AND LATCHES					
1	PAHHZ	80063	SCD200140	.DOOR LATCH ASSY	1
2	PAHZZ	96906	MS171659	..PIN,SPRING	1
3	PAHZZ	80063	SMB113596-1	..HANDLE,DOOR	1
4	XDHZZ	96906	MS35674-41	..PIN,GROOVED,HEADLES	1
5	XDHZZ	81337	SM-C-113597	..HANDLE,DOOR OUTSIDE	1
6	PAHZZ	96906	MS171659	...PIN,SPRING	1
7	XDHZZ	80063	SM-B-113596-2	...HANDLE,MODIFIED	1
8	PAHZZ	96906	MS29513-115	...PACKING,PREFORMED	1
9	XAHZZ	30817	97-154K	...SHIELD,SHAFT	1
10	XAHZZ	80063	SC-B-200155-1	...SHAFT,LATCH HANDLE	1
11	PBOZZ	96906	MS171526	..PIN	3
12	PAHZZ	96906	MS20392-5C33	..PIN,STRAIGHT,HEADED	1
13	PAHZZ	96906	MS20392-5C23	..PIN,STRAIGHT,HEADED	2
14	PAHZZ	88044	AN960C616L	..WASHER,FLAT	3
15	XDHZZ	81337	SC-D-563202GRII	..ROD,STRAIGHT,HEADLE	1
16	PAHZZ	80063	SCD563202GRI	..ROD,SPECIAL	1
17	PAHZZ	80063	SCC200141	..LATCH ARM ASSEMBLY	3
18	XDHZZ	80063	SM-B-162200	..BOLT,CARRIAGE	2
19	XDHZZ	96906	MS17830-10C	..NUT,SELF-LOCKING,HE	2
20	XDHZZ	80063	SCB200146	..WASHER,FLAT	2
21	XDHZZ	80063	SCB200145	..SPACER,SLEEVE	2
22	XDHZZ	80063	SC-B-595073	..DETENT	1
23	XDHZZ	80063	SC-D-200140-8	..WASHER,SHIM	V
24	PAHZZ	81337	SMB615259-1	..SPACER,PLATE	2
25	PAHZZ	80063	SMB615259-2	..SPACER,RING	1
26	XDHZZ	80063	SCB200150	..NUT,BEARING SLEEVE	1
27	XDHZZ	80063	SCB200151	..SLEEVE,SHAFT	1
28	PAHZZ	96906	MS51957-64	..SCREW,MACHINE	1
29	PAHZZ	96906	MS35338-157	..WASHER,LOCK	1
30	PAOZZ	80063	SC-C-595537	..PADLOCK INCLUDES ATTACHING CABLE	1
31	XBFZZ	96906	MS35435-66	..SCREW, WOOD RD HD NO. 8 X 3/4 IN.	2
32	XDHZZ	80063	SM-C-615255	..PLATE,ESCUTCHEON	1
33	PAHZZ	96906	MS35914-149	..INSERT,SCREW THREAD	1
34	PAHZZ	96906	MS35307-307	..SCREW,CAP,HEXAGON H	2
35	PAHZZ	96906	MS35338-158	..WASHER,LOCK	4
36	PAHZZ	96906	MS35307-308	..SCREW,CAP,HEXAGON H	2
37	XAHZZ	80063	SC-B-781197	..LATCH LOCK ASSEMBLY	1
38	XDHZZ	80063	SC-B-200153-2	..SPACER,PLATE	2
39	XDHZZ	80063	SC-B-200153-1	..SHIM,KEEPER SELECT	2
40	XDHZZ	96906	MS35914-151	..INSERT,SCREW THREAD	4
41	PAHZZ	07707	AD64S	..RIVET,BLIND	8
42	XDHZZ	80063	SM-B-555598-1	..LATCH,RIM	2
43	PAHZZ	96906	MS35649-202	..NUT,PLAIN,HEXAGON	4
44	PAHZZ	96906	MS35338-43	..WASHER,LOCK	4
45	PAHZZ	96906	MS35206-273	..SCREW,MACHINE	4
46	PAHZZ	96906	MS27183-8	..WASHER,FLAT	4
47	PAHZZ	80063	SMB555598-2	..STRIKE,CATCH	1

END OF FIGURE

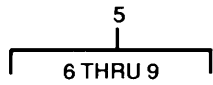

Figure 6. Towing Eye Assembly.

(1) ITEM NO	(2) SMR CODE	(3) CAGEC	(4) PART NUMBER	(5) DESCRIPTION AND USABLE ON CODES (UOC)	(6) QTY
GROUP 03 TOWING EYE ASSEMBLY					
FIG. 6 TOWING EYE ASSEMBLY					
1	PAFZZ	96906	MS35307-364	SCREW,CAP,HEXAGON H	8
2	PAFZZ	96906	MS35338-141	WASHER,LOCK	8
3	PAFZZ	96906	MS15795-815	WASHER,FLAT	8
4	XDFZZ	80063	SM-B-555568-1	SCREW,CAP,SOCKET HE	24
5	XDFZZ	81337	SM-D-317088GRI	TOWING EYE ASSEMBLY FRONT LEFT	1
5	XDFZZ	80063	SM-D-317088GRII	TOWING EYE ASSEMBLY FRONT RIGHT	1
5	XDFZZ	80063	SM-D-317088GRIII	TOWING EYE ASSEMBLY REAR LEFT	1
5	XDFZZ	80063	SMD317088GR1V	TOWING EYE ASSEMBLY REAR RIGHT	1
6	PAFZZ	96906	MS21044N7	.NUT,SELF-LOCKING,HE	1
7	PAFZZ	88044	AN7C22A	.BOLT,MACHINE	1
8	PAFZZ	80063	SMB165462	.CLAMP,MATERIAL LIFT	1
9	XDFZZ	80063	SM-D-317087-1	.BRACKET,EYE,ROTATIN FRONT RIGHT	1
9	XBFZZ	80063	SM-D-317087-2	.BRACKET,EYE,ROTATIN FRONT LEFT	1
9	XDFZZ	80063	SM-D-317087-3	.BRACKET,EYE,ROTATIN REAR LEFT	1
9	XDFZZ	80063	SM-D-317087-4	.BRACKET,EYE,ROTATIN REAR RIGHT	1
10	PAFZZ	81337	SM-B-165483-1	SPACER,PLATE	4
11	XDFZZ	80063	SM-B-165483-3	SPACER,PLATE	4

END OF FIGURE

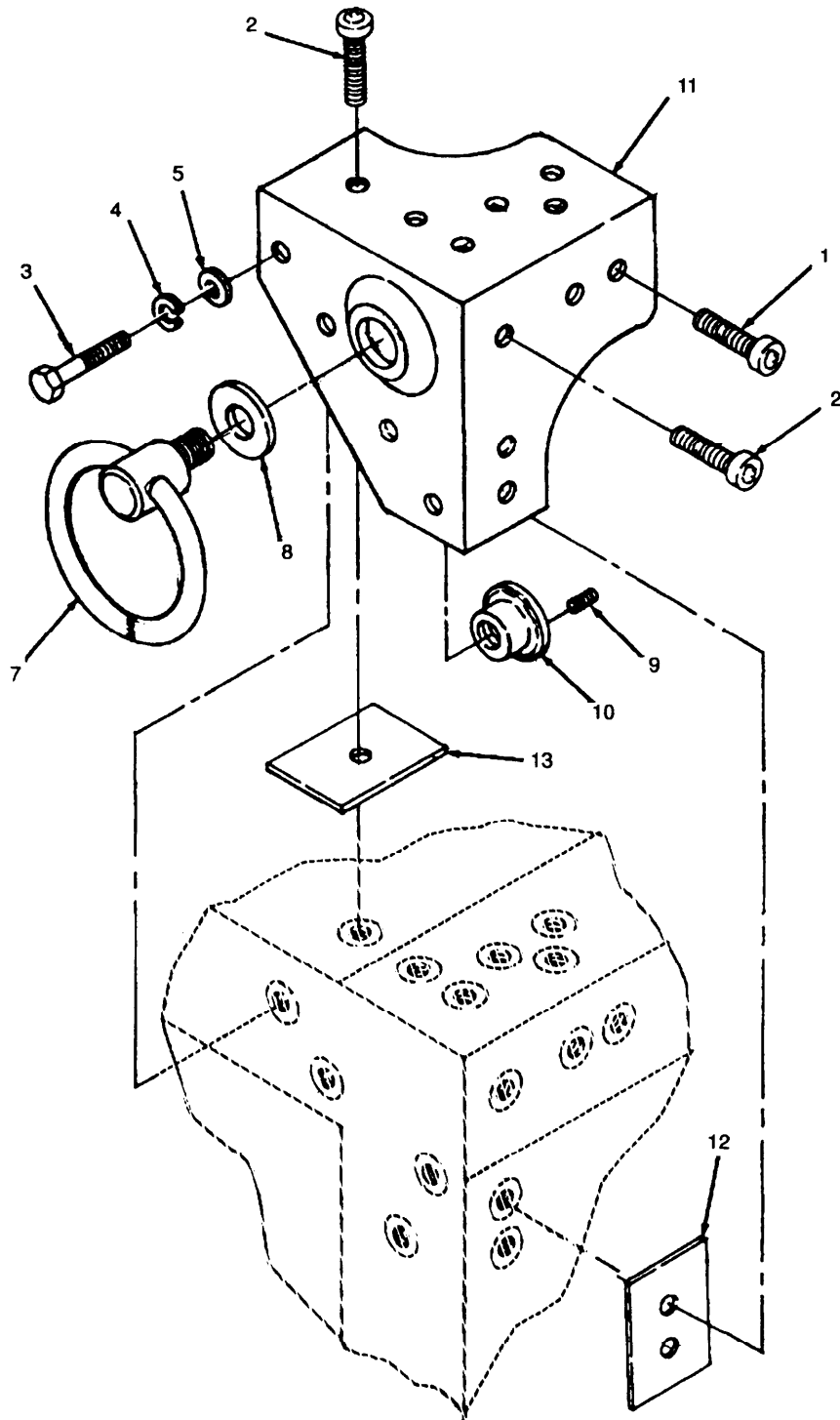
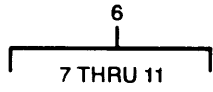
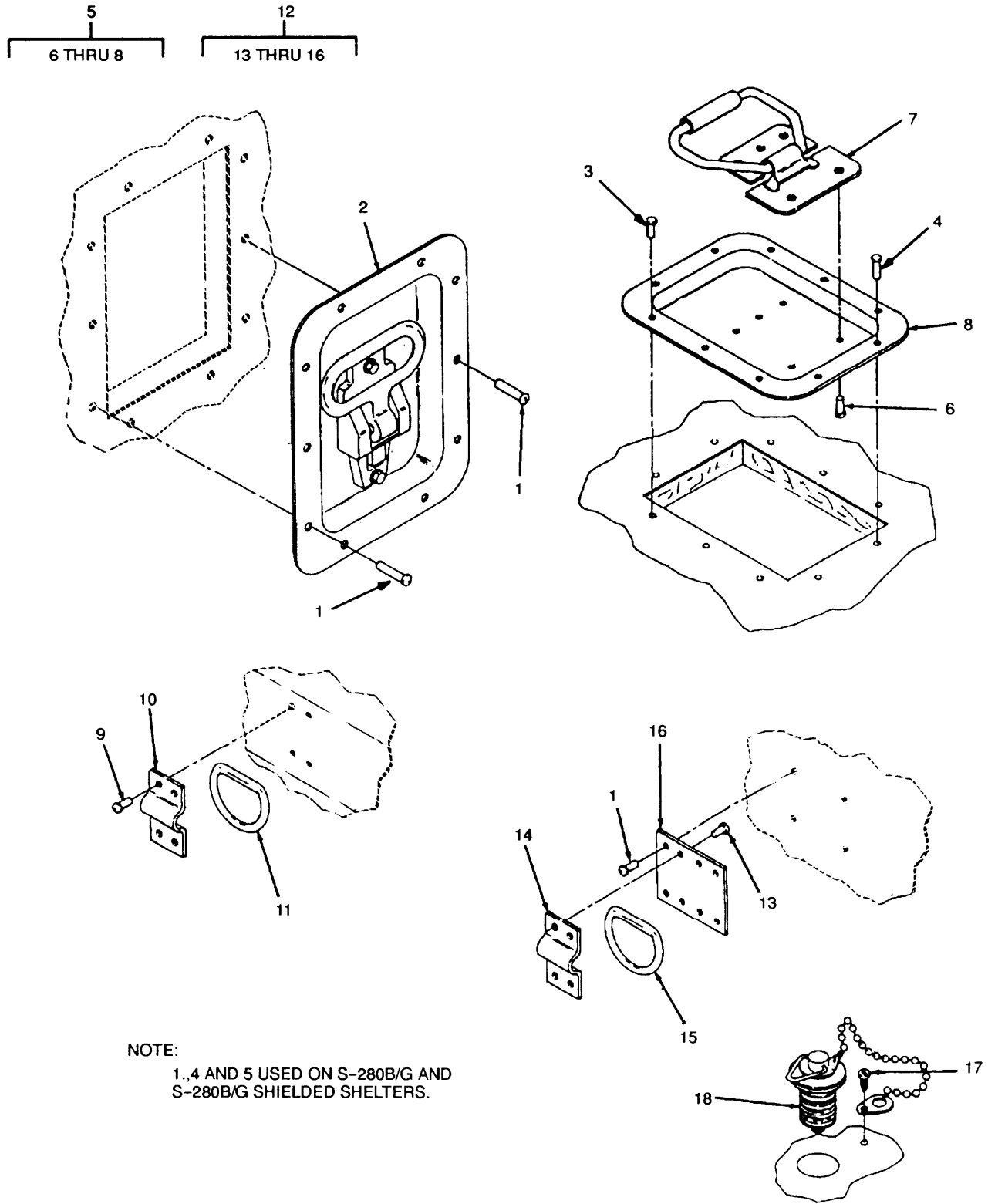

Figure 7. Lifting Eye Assembly.

(1) ITEM NO	(2) SMR CODE	(3) CAGEC	(4) PART NUMBER	(5) DESCRIPTION AND USABLE ON CODES (UOC)	(6) QTY
GROUP 04 LIFTING EYE ASSEMBLY					
FIG. 7 LIFTING EYE ASSEMBLY					
1	XDFZZ	80063	SM-B-555568-3	SCREW,CAP, SOCKET HE	8
2	XDFZZ	80063	SM-B-555568-2	SCREW,CAP, SOCKET HE	8
3	PAFZZ	96906	MS35307-362	SCREW,CAP, HEXAGON H	16
4	PAFZZ	96906	MS35338-141	WASHER, LOCK	16
5	PAHZZ	96906	MS15795-815	WASHER, FLAT	16
6	PBFFZ	81337	SM-D-555537GRI	LIFTING EYE ASSEMBL REAR LEFT	1
6	PAOZZ	81337	SM-D-555537GRII	LIFTING EYE ASSY REAR LIGHT	1
6	PAFZZ	81337	SM-D-555537GRIII	LIFTING EYE ASSEMBL FRONT LEFT	1
6	PAFZZ	81337	SM-D-555537GRIV	LIFTING EYE ASSEMBL FRONT RIGHT	1
7	XDFZZ	80063	SM-C-555540	.BOLT,RING	1
8	PAFZZ	80063	SMB555547	.SPACER,PLATE	1
9	PBOZZ	96906	MS51021-42	.SETSCREW	4
10	XDFZZ	80063	SM-C-555548	.PIN, STRAIGHT, HEADED	1
11	XDFZZ	80063	SM-D-555536-1	.CAST LIFT RLH REAR LEFT	1
11	XDFZZ	80063	SM-D-555536-2	.BRACKET,EYE, ROTATIN REAR RIGHT	1
11	XDHZZ	80063	SM-D-555536-3	.CASTING,LIFT FLH FRONT LEFT	1
11	PAFZZ	80063	SMD555536-4	.CAST LIFT FRH FRONT RIGHT	1
12	XDFZZ	80063	SM-B-165483-2	SPACER,PLATE	4
13	XDFZZ	80063	SM-B-165483-1	SPACER,PLATE	4

END OF FIGURE



NOTE:
 1, 4 AND 5 USED ON S-280B/G AND
 S-280B/G SHIELDED SHELTERS.

Figure 8. Steps, Hand Holds and Drain Plug.

(1) ITEM NO	(2) SMR CODE	(3) CAGEC	(4) PART NUMBER	(5) DESCRIPTION AND USABLE ON CODES (UOC)	(6) QTY
GROUP 05 STEPS, HAND HOLDS AND DRAIN PLUG					
FIG. 8 STEPS, HAND HOLDS AND DRAIN PLUG					
1	PAFZZ	96906	MS20470AD6-8	RIVET,SOLID	38
2	PAFZZ	19220	AL3-575709	FOLDING STEP ASSY	3
3	PAFZZ	07707	AD42S	RIVET,BLIND	6
4	PAFZZ	07707	AD43S	RIVET,BLIND	4
5	PAHZZ	13175	SMC165382	HANDHOLD ASSEMBLY	1
6	PAHZZ	96906	MS20470AD6-8	.RIVET,SOLID	5
7	PAHZZ	98003	H945SS2RG	.HANDLE,BAIL	1
8	XDHZZ	80063	SM-C-165383	.PAN,HANDHOLD	1
9	XBFZZ	96906	MS20426-AD6	RIVET,BLIND	20
10	XDFZZ	80063	SM-B-165331	CLAMP	2
11	XAFZZ	80063	SM-B-165399	D RING	2
12	XDFZZ	80063	SM-B-165332	D-RING ASSEMBLY	2
13	PAFZZ	96906	MS20426AD6-8	.RIVET,SOLID	4
14	XDFZZ	80063	SM-B-165331	.CLAMP	1
15	XDFZZ	80063	SM-B-165399	.D-RING	1
16	XDFZZ	80063	SM-B-165332-1	.PLATE	1
17	XBFZZ	96906	MS35494-131	SCREW,WOOD	1
18	PAOZZ	80063	SMB165452	STOPPER,WASTE DRAIN INCLUDES ATTACHING CHAIN	1

END OF FIGURE

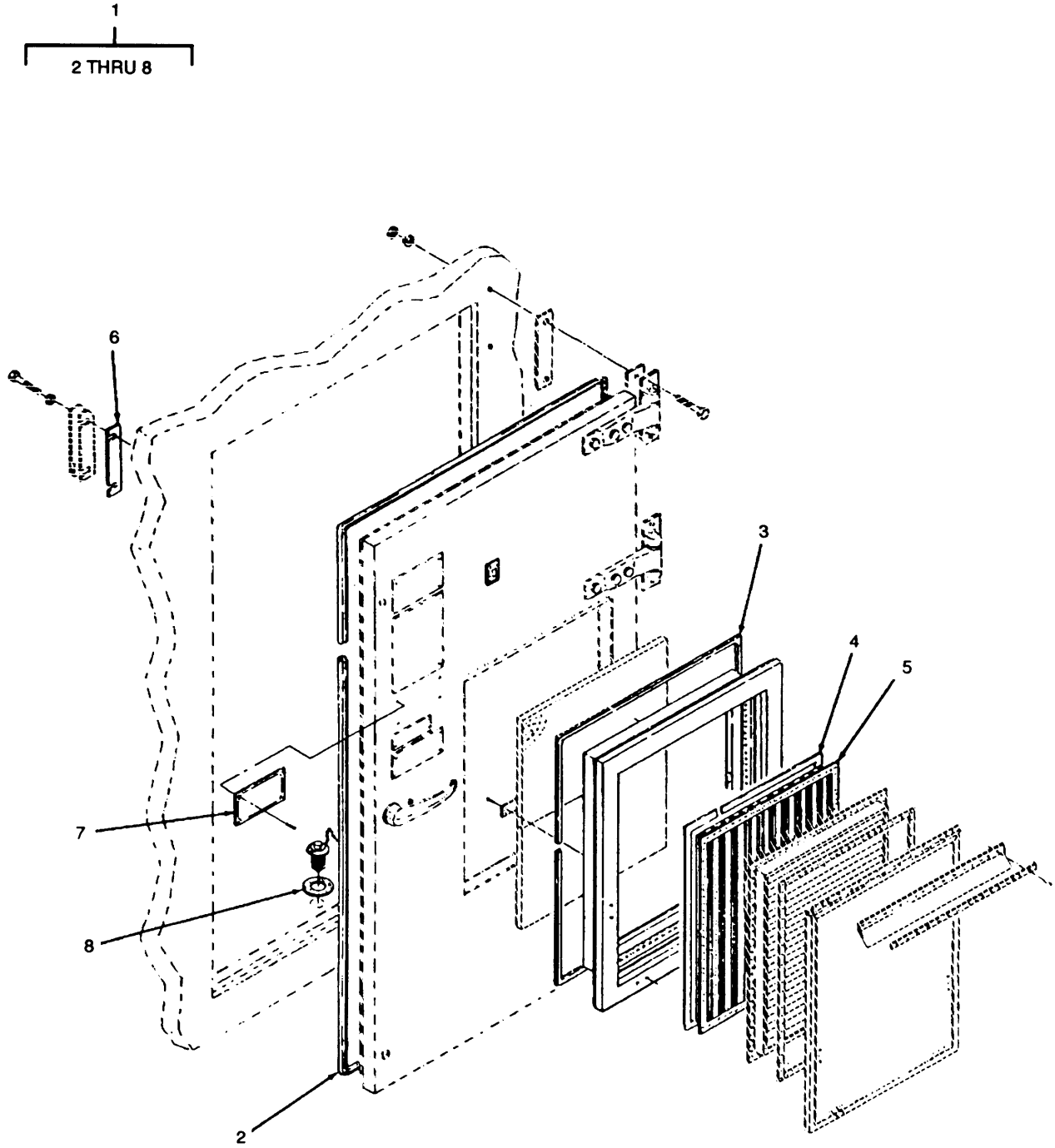

Figure 9. RFI Components.

(1) ITEM NO	(2) SMR CODE	(3) CAGEC	(4) PART NUMBER	(5) DESCRIPTION AND USABLE ON CODES (UOC)	(6) QTY
GROUP 06 RFI COMPONENTS					
FIG. 9 RFI COMPONENTS					
1	PAHZZ	80058	MK1079G	MODIFICATION KIT UOC:EKV	1
2	XDHZZ	80063	SMB564670-3	.WIRE MESH,KNITTED UOC:EKV	1
3	XDHZZ	80063	SM-B-564670-4	.SHIELDING GASKET,EL UOC:EKV	1
4	XDFZZ	80063	SM-B-563756	.SEALING COMPOUND UOC:EKV	V
5	PAOZZ	80063	SM-C-450478	.FILTER ELEMENT,AIR UOC:EKV	1
6	XBFZZ	80063	SC-B-200133	.SHIM, KEEPER UOC:EKV	4
7	XDOZZ	80063	SM-B-165463	.PLATE, NAME UOC:EKV	1
8	PBFZZ	81337	SM-B-374181	.WASHER,FLAT UOC:EKV	1

END OF FIGURE

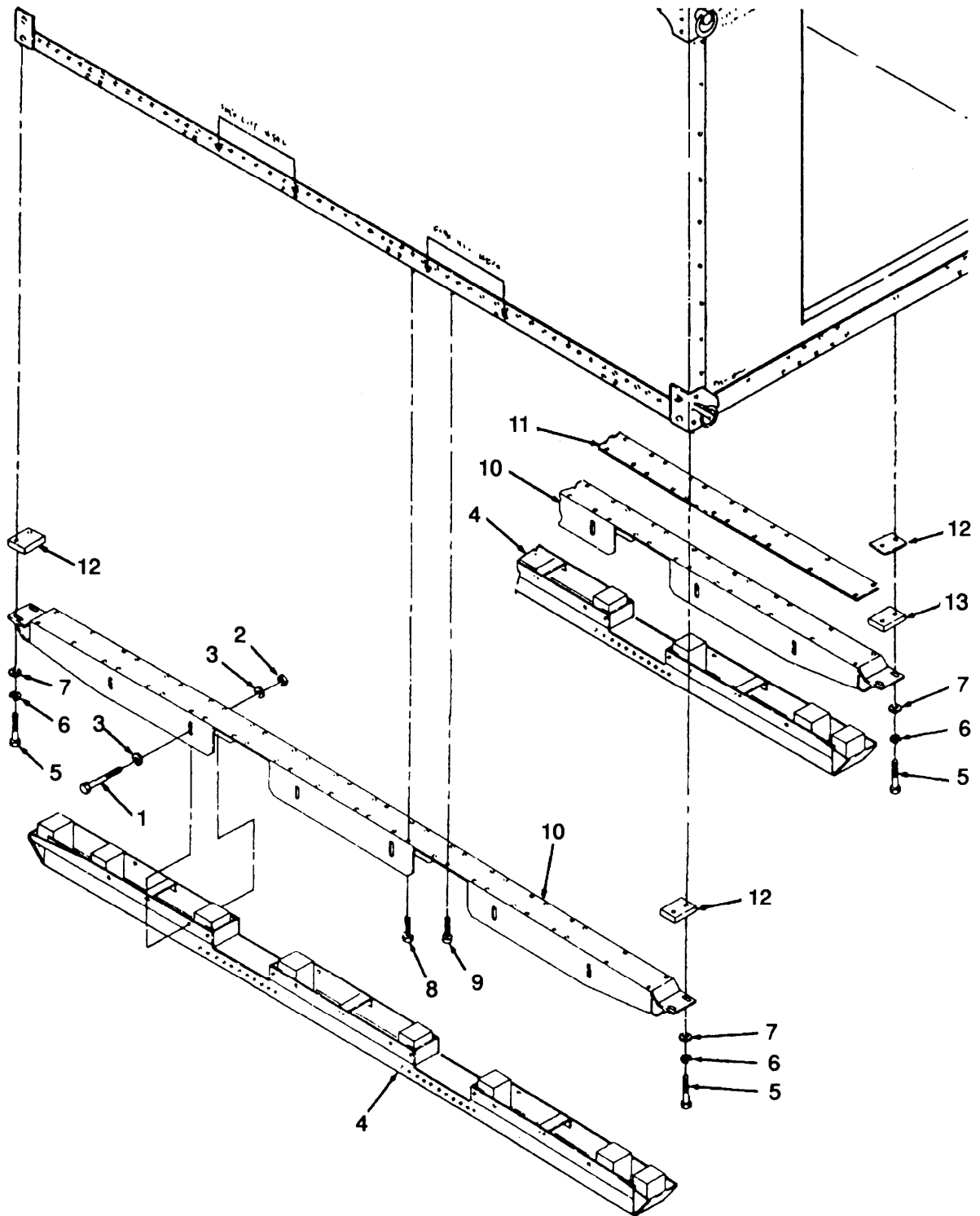

Figure 10. Skid Assembly and Mounting Brackets.

(1) ITEM NO	(2) SMR CODE	(3) CAGEC	(4) PART NUMBER	(5) DESCRIPTION AND USABLE ON CODES (UOC)	(6) QTY
GROUP 07 SKID ASSEMBLY AND MOUNTING BRACKETS					
FIG. 10 SKID ASSEMBLY AND MOUNTING BRACKETS					
1	XBHZZ	80063	SM-B-162201	BOLT, HEX HEAD	18
2	PAHZZ	96906	MS17830-6C	NUT, SELF-LOCKING, HE	18
3	PAFZZ	96906	MS15795-815	WASHER, FLAT	36
4	XBHHH	80063	SM-D-162194	SKID ASSEMBLY	3
5	PAHZZ	96906	MS35307-338	BOLT, MACHINE	12
6	PAHZZ	96906	MS35338-140	WASHER, LOCK	12
7	PAHZO	96906	MS15795-813	WASHER, FLAT	12
8	PAHZZ	96906	MS35307-306	SCREW, CAP, HEXAGON H	132
9	PAFZZ	96906	MS35191-273	SCREW, MACHINE	24
10	XBHZZ	80063	SC-D-595499	SKID, ADAPTER	3
11	XDHZZ	80063	SC-D-595500	SPACER, PLATE	1
12	XDHZZ	81337	SM-B-162196-1	SHIM, SKID MT	6
13	XDHZZ	80063	SM-C-555549	SHIM, CENTER, SKID	V

END OF FIGURE

SECTION IV

TM 10-5411-206-24P

CROSS-REFERENCE INDEXES

NATIONAL STOCK NUMBER INDEX					
STOCK NUMBER	FIG.	ITEM	STOCK NUMBER	FIG.	ITEM
5365-00-001-1944	7	8	5305-00-717-5467	7	3
5320-00-005-6248	3	17	5305-00-753-4451	7	9
4130-00-007-2526	9	5	5340-00-793-1099	5	16
5410-00-007-5164	2	10	5340-00-794-4440	5	1
5305-00-021-3620	5	34	5340-00-794-4610	5	3
5305-00-021-3740	6	1	5310-00-802-4701	10	7
5365-00-037-8762	5	25	5310-00-807-1469	3	2
5310-00-045-3296	5	44	5310-00-809-8546	5	46
5310-00-050-6646	10	2	5315-00-816-1794	2	4
5305-00-050-9230	5	28	5340-00-836-1938	8	7
5305-00-052-7436	2	2	5315-00-846-8337	5	2
5320-00-057-7208	4	9		5	6
5320-00-069-0055	4	12	5310-00-869-9576	5	29
5315-00-075-5828	5	13	5320-00-874-4471	1	1
5310-00-080-6004	2	15	5320-00-882-8385	3	20
5305-00-082-6721	1	16	5320-00-882-8386	1	2
5310-00-088-0552	6	6	5310-00-883-9417	5	35
9330-00-107-1165	4	14	5340-00-917-6104	3	5
5320-00-117-6853	8	1	3040-00-919-5049	7	11
	8	6	5310-00-925-9671	4	5
5320-00-117-7288	8	13	5310-00-929-6452	1	21
9320-00-134-9663	3	19	5410-00-933-0845	8	5
5306-00-139-7381	2	13	2540-00-933-4064	7	6
5306-00-139-7382	2	16	4510-00-933-9953	8	18
5340-00-143-0394	5	33	5310-00-934-9758	5	43
5365-00-173-7010	5	24	2540-00-937-0325	7	6
5310-00-177-7674	1	22	9999-00-937-5248	9	1
5330-00-179-0303	3	13	5310-00-937-5949	1	20
	4	2	5320-00-952-4159	5	41
5306-00-182-1513	3	4	5320-00-952-4162	8	4
5306-00-182-1514	3	1	5310-00-955-6219	1	18
5310-00-1834355	5	14	5315-00-957-2649	5	12
5305-00-207-8253	5	36	5320-00-957-3582	8	3
5340-00-229-5747	5	17	5310-00-974-6623	10	6
5330-00-248-3847	5	8	5310-00-984-7042	6	2
5305-00-253-5625	2	6		7	4
	3	14	5305-00-984-7341	1	17
4010-00-436-3300	2	5		10	9
5320-00-451-9162	4	7	5305-00-984-7364	5	45
5340-00-493-9235	5	47	5320-00-993-7355	4	10
5305-00-533-5446	2	1	1015-01-019-7117	5	11
5320-00-582-3304	1	4	5340-01-114-2139	8	2
	1	10	5340-01-154-5276	2	18
5306-00-584-4911	6	7	5340-01-155-3503	1	13
5310-00-595-6057	6	3	5410-01-183-2376	2	17
	7	5	5340-01-239-8705	5	30
	10	3	5410-01-276-7663	2	3
5310-00-625-5756	3	3	5365-01-321-2481	6	10
5306-00-637-8062	1	12	5310-01-344-6751	9	8
5306-00-655-6170	10	5	5365-01-360-9993	4	8
5305-00-702-4523	10	8			

SECTION IV

TM 10-5411-206-24P

CROSS-REFERENCE INDEXES

CAGEC	PART NUMBER	PART NUMBER INDEX STOCK NUMBER	FIG.	ITEM
07707	AD42S	5320-00-957-3582	8	3
07707	AD43S	5320-00-952-4162	8	4
07707	AD45H	5320-00-874-4471	1	1
07707	AD64S	5320-00-952-4159	5	41
07707	AD66H	5320-00-882-8385	3	20
19220	AL3-575709	5340-01-114-2139	8	2
88044	AN101011	5306-00-637-8062	1	12
88044	AN5C25A	5306-00-182-1513	3	4
88044	AN5C26A	5306-00-182-1514	3	1
88044	AN7C22A	5306-00-584-4911	6	7
88044	AN960C616L	5310-00-183-4355	5	14
98003	H945SS2RG	5340-00-836-1938	8	7
80058	MK1079G	9999-00-937-5248	9	1
96906	MS15795-812	5310-00-625-5756	3	3
96906	MS15795-813	5310-00-802-4701	10	7
96906	MS15795-815	5310-00-595-6057	6	3
			7	5
			10	3
96906	MS16562-237		3	6
96906	MS171526	1015-01-019-7117	5	11
96906	MS171659	5315-00-846-8337	5	2
			5	6
96906	MS17830-10C		5	19
96906	MS17830-6C	5310-00-050-6646	10	2
96906	MS20392-5C23	5315-00-075-5828	5	13
96906	MS20392-5C33	5315-00-957-2649	5	12
96906	MS20426-AD6		8	9
96906	MS20426AD6-8	5320-00-117-7288	8	13
96906	MS20470AD6-8	5320-00-117-6853	8	1
			8	6
96906	MS20600AD4W2	5320-00-582-3304	1	4
			1	10
96906	MS21042-5	5310-00-807-1469	3	2
96906	MS21044N7	5310-00-088-0552	6	6
96906	MS 2 1 3 1 8 - 4 6	5305-00-253-5625	2	6
			3	14
96906	MS24617-54	5305-00-052-7436	2	2
96906	MS24655-281		2	12
96906	MS24665-285	5315-00-816-1794	2	4
96906	MS27183-14	5310-00-080-6004	2	15
96906	MS27183-8	5310-00-809-8546	5	46
96906	MS29513-115	5330-00-248-3847	5	8
96906	MS35191-273	5305-00-984-7341	1	17
			10	9
96906	MS35206-273	5305-00-984-7364	5	45
96906	MS35307-306	5305-00-702-4523	10	8
96906	MS35307-307	5305-00-021-3620	5	34
96906	MS35307-308	5305-00-207-8253	5	36
96906	MS35307-338	5306-00-655-6170	10	5
96906	MS35307-362	5305-00-717-5467	7	3
96906	MS35307-364	5305-00-021-3740	6	1

SECTION IV

TM 10-5411-206-24P

CROSS-REFERENCE INDEXES

CAGEC	PART NUMBER	PART NUMBER INDEX STOCK NUMBER	FIG.	ITEM
96906	MS35338-140	5310-00-974-6623	10	6
96906	MS35338-141	5310-00-984-7042	6	2
			7	4
96906	MS35338-157	5310-00-869-9576	5	29
96906	MS35338-158	5310-00-883-9417	5	35
96906	MS35338-43	5310-00-045-3296	5	44
96906	MS35435-66		5	31
96906	MS35493-53	5305-00-533-5446	2	1
96906	MS35494-131		8	17
96906	MS35649-202	5310-00-934-9758	5	43
96906	MS35674-41		5	4
96906	MS35914-149	5340-00-143-0394	5	33
96906	MS35914-151		5	40
96906	MS51021-42	5305-00-753-4451	7	9
96906	MS5171536		2	11
96906	MS51957-64	5305-00-050-9230	5	28
96906	MS51957-81	5305-00-082-6721	1	16
81349	M24243/6-A404H	5320-00-882-8386	1	2
80205	NAS1398D4-3	5320-00-069-0055	4	12
			4	13
80205	NAS1398D4-4	5320-00-057-7208	4	9
80205	NAS1398D6A3	5320-00-005-6248	3	17
80205	NAS1399D4-4	5320-00-993-7355	4	10
80205	NAS1515H4L	5310-00-925-9671	4	5
80205	NAS1739E4-3	5320-00-451-9162	4	7
80063	SC-B-200133		9	6
80063	SC-B-200153-1		5	39
80063	SC-B-200153-2		5	38
80063	SC-B-200155-1		5	10
80063	SC-B-595073		5	22
80063	SC-B-595081		4	11
80063	SC-B-781197		5	37
80063	SC-B-781199		2	8
80063	SC-C-200157	5340-01-154-5276	2	18
80063	SC-C-200158	5410-01-183-2376	2	17
80063	SC-C-595537	5340-01-239-8705	5	30
80063	SC-D-200140-8		5	23
81337	SC-D-563202GR II		5	15
80063	SC-D-595078	5410-00-007-5164	2	10
96906	SC-D-595078-1		2	14
80063	SC-D-595499		10	10
80063	SC-D-595500		10	11
81337	SC-D-595548	5410-01-276-7663	2	3
80063	SCB200145		5	21
80063	SCB200146		5	20
80063	SCB200150		5	26
80063	SC8200151		5	27
81337	SCC200135	5340-01-155-3503	1	13
80063	SCC200141	5340-00-229-5747	5	17
80063	SCD200140	5340-00-794-4440	5	1
80063	SCD563202GRI	5340-00-793-1099	5	16

CROSS-REFERENCE INDEXES

CAGEC	PART NUMBER	PART NUMBER INDEX		FIG.	ITEM
			STOCK NUMBER		
80063	SM-B-113596-2			5	7
81337	SM-B-162196-1			10	12
80063	SM-B-162197			3	11
80063	SM-B-162200			5	18
80063	SM-B-162201			10	1
80063	SM-B-165303			1	3
80063	SM-B-165331			8	10
				8	14
80063	SM-B-165332			8	12
80063	SM-B-165332-1			8	16
80063	SM-B-165399			8	11
				8	15
80063	SM-B-165463			1	7
				9	7
81337	SM-B-165483-1		5365-01-321-2481	6	10
				7	13
80063	SM-B-165483-2			7	12
80063	SM-B-165483-3			6	11
80063	SM-B-317089			1	9
80063	SM-B-317129			3	8
80063	SM-B-340031			1	8
81337	SM-B-374181		5310-01-344-6751	9	8
80063	SM-B-450435			4	19
80063	SM-B-450447			4	6
81337	SM-B-450448		5365-01-360-9993	4	8
80063	SM-B-450465			3	18
80063	SM-B-508785			3	7
80063	SM-B-555555			1	5
80063	SM-B-555568-1			6	4
80063	SM-B-555568-2			7	2
80063	SM-B-555568-3			7	1
80063	SM-B-555572-6		9320-00-134-9663	3	19
80063	SM-B-555598-1			5	42
80063	SM-B-563756			9	4
80063	SM-B-564670-4			9	3
81337	SM-B-615256			1	11
81337	SM-B-113597			5	5
80063	SM-C-165383			8	8
80063	SM-C-165466			1	6
80063	SM-C-340028			2	9
80063	SM-C-450443			3	16
80063	SM-C-450466		9330-00-107-1165	4	14
80063	SM-C-450478		4130-00-007-2526	9	5
80063	SM-C-508745			4	21
80063	SM-C-508783			3	10
80063	SM-C-508784			3	9
80063	SM-C-555540			7	7
80063	SM-C-555548			7	10
80063	SM-C-555549			10	13
80063	SM-C-564811			1	14
80063	SM-C-564839-106IN			4	3

CROSS-REFERENCE INDEXES

CAGEC	PART NUMBER	PART NUMBER INDEX		FIG.	ITEM
		STOCK NUMBER			
80063	SM-C-615255			5	32
80063	SM-C-615262-1			4	16
80063	SM-C-615262-2			4	17
80063	SM-C-615263			3	15
80063	SM-D-162194			10	4
80063	SM-D-317087-1			6	9
80063	SM-D-317087-2			6	9
80063	SM-D-317087-3			6	9
80063	SM-D-317087-4			6	9
81337	SM-D-317088GRI			6	5
80063	SM-D-317088GR II			6	5
80063	SM-D-317088GR III			6	5
80063	SM-D-450461			3	12
80063	SM-D-450462			4	1
				4	20
80063	SM-D-450462-10			4	15
81337	SM-D-508738			3	21
81337	SM-D-55537GR III			7	6
80063	SM-D-555536-1			7	11
80063	SM-D-555536-2			7	11
80063	SM-D-555536-3			7	11
81337	SM-D-555537GRI	2540-00-937-0325		7	6
81337	SM-D-555537GR II			7	6
81337	SM-D-555537GR IV	2540-00-933-4064		7	6
80063	SM-D-615264			4	18
80063	SMB113596-1	5340-00-794-4610		5	3
80063	SMB165452	4510-00-933-9953		8	18
80063	SMB165462			6	8
80063	SMB340027	4010-00-436-3300		2	5
80063	SMB555547	5365-00-001-1944		7	8
80063	SMB555598-2	5340-00-493-9235		5	47
80063	SMB564670-3			9	2
80063	SMB564727-1	5306-00-139-7382		2	16
80063	SMB564727-2	5306-00-139-7381		2	13
81337	SMB615259-1	5365-00-173-7010		5	24
80063	SMB615259-2	5365-00-037-8762		5	25
13175	SMC165382	5410-00-933-0845		8	5
80063	SMC317057	5340-00-917-6104		3	5
80063	SMC564839-96IN	5330-00-179-0303		3	13
				4	2
80063	SMD317088GR IV			6	5
80063	SMD555536-4	3040-00-919-5049		7	11
25472	S10B130	5310-00-955-6219		1	18
03481	S10B216	5310-00-177-7674		1	22
03481	S25B211	5310-00-929-6452		1	21
03481	S31B275			1	19
83187	S31B500	5310-00-937-5949		1	20
25472	S37B285			1	15
70892	13AN0FFSET			2	7
72962	2INTU040			4	4
30817	97-154K			5	9

CROSS-REFERENCE INDEXES

FIGURE AND ITEM NUMBER INDEX				
FIG.	ITEM	STOCK NUMBER	CAGEC	PART NUMBER
1	1	5320-00-874-4471	07707	AD45H
1	2	5320-00-882-8386	81349	M24243/6-A404H
1	3		80063	SM-B-165303
1	4	5320-00-582-3304	96906	MS20600AD4W2
1	5		80063	SM-B-555555
1	6		80063	SM-C-165466
1	7		80063	SM-B-165463
1	8		80063	SM-B-340031
1	9		80063	SM-B-317089
1	10	5320-00-582-3304	96906	MS20600AD4W2
1	11		81337	SM-B-615256
1	12	5306-00-637-8062	88044	AN101011
1	13	5340-01-155-3503	81337	SCC200135
1	14		80063	SM-C-564811
1	15		25472	S37B285
1	16	5305-00-082-6721	96906	MS51957-81
1	17	5305-00-984-7341	96906	MS35191-273
1	18	5310-00-955-6219	25472	S10B130
1	19		03481	S31B275
1	20	5310-00-937-5949	83187	S31B500
1	21	5310-00-929-6452	03481	S25B211
1	22	5310-00-177-7674	03481	S10B216
2	1	5305-00-533-5446	96906	MS35493-53
2	2	5305-00-052-7436	96906	MS24617-54
2	3	5410-01-276-7663	81337	SC-D-595548
2	4	5315-00-816-1794	96906	MS24665-285
2	5	4010-00-436-3300	80063	SMB340027
2	6	5305-00-253-5625	96906	MS21318-46
2	7		70892	13ANOFFSET
2	8		80063	SC-B-781199
2	9		80063	SM-C-340028
2	10	5410-00-007-5164	80063	SC-D-595078
2	11		96906	MS5171536
2	12		96906	MS24655-281
2	13	5306-00-139-7381	80063	SMB564727-2
2	14		96906	SC-D-595078-1
2	15	5310-00-080-6004	96906	MS27183-14
2	16	5306-00-139-7382	80063	SMB564727-1
2	17	5410-01-183-2376	80063	SC-C-200158
2	18	5340-01-154-5276	80063	SC-C-200157
3	1	5306-00-182-1514	88044	AN5C26A
3	2	5310-00-807-1469	96906	MS21042-5
3	3	5310-00-625-5756	96906	MS15795-812
3	4	5306-00-182-1513	88044	AN5C25A
3	5	5340-00-917-6104	80063	SMC317057
3	6		96906	MS16562-237
3	7		80063	SM-B-508785
3	8		80063	SM-B-317129
3	9		80063	SM-C-508784
3	10		80063	SM-C-508783
3	11		80063	SM-B-162197

SECTION IV

TM 10-5411-206-24P

CROSS-REFERENCE INDEXES
FIGURE AND ITEM NUMBER INDEX

FIG.	ITEM	STOCK NUMBER	CAGEC	PART NUMBER
3	12		80063	SM-D-450461
3	13	5330-00-179-0303	80063	SMC564839-961N
3	14	5305-00-253-5625	96906	MS21318-46
3	15		80063	SM-C-615263
3	16		80063	SM-C-450443
3	17	5320-00-005-6248	80205	NAS1398D6A3
3	18		80063	SM-B-450465
3	19	9320-00-134-9663	80063	SM-B-555572-6
3	20	5320-00-882-8385	07707	AD66H
3	21		81337	SM-D-508738
4	1		80063	SM-D-450462
4	2	5330-00-179-0303	80063	SMC564839-961N
4	3		80063	SM-C-564839-1061N
4	4		72962	21NTU040
4	5	5310-00-925-9671	80205	NAS1515H4L
4	6		80063	SM-B-450447
4	7	5320-00-451-9162	80205	NAS1739E4-3
4	8	5365-01-360-9993	81337	SM-B-450448
4	9	5320-00-057-7208	80205	NAS1398D4-4
4	10	5320-00-993-7355	80205	NAS1399D4-4
4	11		80063	SC-B-595081
4	12	5320-00-069-0055	80205	NAS1398D4-3
4	13		80205	NAS1398D4-3
4	14	9330-00-107-1165	80063	SM-C-450466
4	15		80063	SM-D-450462-10
4	16		80063	SM-C-615262-1
4	17		80063	SM-C-615262-2
4	18		80063	SM-D-615264
4	19		80063	SM-B-450435
4	20		80063	SM-D-450462
4	21		80063	SM-C-508745
5	1	5340-00-794-4440	80063	SCD200140
5	2	5315-00-846-8337	96906	MS171659
5	3	5340-00-794-4610	80063	SMB113596-1
5	4		96906	MS35674-41
5	5		81337	SM-C-113597
5	6	5315-00-846-8337	96906	MS171669
5	7		80063	SM-B-113596-2
5	8	5330-00-248-3847	96906	MS29513-115
5	9		30817	97-154K
5	10		80063	SC-B-200155-1
5	11	1015-01-019-7117	96906	MS171526
5	12	5315-00-957-2649	96906	MS20392-5C33
5	13	5315-00-075-5828	96906	MS20392-5C23
5	14	5310-00-183-4355	88044	AN960C616L
5	15		81337	SC-D-563202GR11
5	16	5340-00-793-1099	80063	SCD563202GR1
5	17	5340-00-229-5747	80063	SCC200141
5	18		80063	SM-B-16220
5	19		96906	MS17830-10C

SECTION IV

TM 10-5411-206-24P

CROSS-REFERENCE INDEXES

FIG.	ITEM	FIGURE AND ITEM STOCK NUMBER	NUMBER INDEX CAGEC	PART NUMBER
5	20		80063	SCB200146
5	21		80063	SCB200145
5	22		80063	SC-B-595073
5	23		80063	SC-D-200140-8
5	24	5365-00-173-7010	81337	SMB615259-1
5	25	5365-00-037-8762	80063	SMB615259-2
5	26		80063	SC8200150
5	27		80063	SCB200151
5	28	5305-00-050-9230	96906	MS51957-64
5	29	5310-00-869-9576	96906	MS35338-157
5	30	5340-01-239-8705	80063	SC-C-595537
5	31		96906	MS35435-66
5	32		80063	SM-C-615255
5	33	5340-00-143-0394	96906	MS35914-149
5	34	5305-00-021-3620	96906	MS35307-307
5	35	5310-00-883-9417	96906	MS35338-158
5	36	5305-00-207-8253	96906	MS35307-308
5	37		80063	SC-B-781197
5	38		80063	SC-B-200153-2
5	39		80063	SC-B-200153-1
5	40		96906	MS35914-151
5	41	5320-00-952-4159	07707	AD64S
5	42		80063	SM-B-555598-1
5	43	5310-00-934-9758	96906	MS35649-202
5	44	5310-00-045-3296	96906	MS35338-43
5	45	5305-00-984-7364	96906	MS35206-273
5	46	5310-00-809-8546	96906	MS27183-8
5	47	5340-00-493-9235	80063	SMB555598-2
6	1	5305-00-021-3740	96906	MS35307-364
6	2	5310-00-984-7042	96906	MS35338-141
6	3	5310-00-595-6057	96906	MS15795-815
6	4		80063	SM-B-555568-1
6	5		80063	SM-D-317088GR II
6	5		80063	SM-D-317088GR III
6	5		80063	SMD317088GR IV
6	5		81337	SM-D-317088GR I
6	6	5310-00-088-0552	96906	MS21044N7
6	7	5306-00-584-4911	88044	AN7C22A
6	8		80063	SMB165462
6	9		80063	SM-D-317087-1
6	9		80063	SM-D-317087-2
6	9		80063	SM-D-3-17087-3
6	9		80063	SM-D-317087-4
6	10	5365-01-321-2481	81337	SM-B-165483-1
6	11		80063	SM-B-165483-3
7	1		80063	SM-B-555568-3
7	2		80063	SM-B-555568-2
7	3	5305-00-717-5467	96906	MS35307-362
7	4	5310-00-984-7042	96906	MS35338-141
7	5	5310-00-595-6057	96906	MS15795-815
7	6		81337	SM-D-55537GR III

CROSS-REFERENCE INDEXES

FIGURE AND ITEM NUMBER INDEX				
FIG.	ITEM	STOCK NUMBER	CAGEC	PART NUMBER
7	6		81337	SM-D-555537GRII
7	6	2540-00-933-4064	81337	SM-D-555537GRIV
7	6	2540-00-937-0325	81337	SM-D-555537GRI
7	7		80063	SM-C-555540
7	8	5365-00-001-1944	80063	SMB555547
7	9	5305-00-753-4451	96906	MS51021-42
7	10		80063	SM-C-555548
7	11		80063	SM-D-555536-1
7	11		80063	SM-D-555536-2
7	11		80063	SM-D-555536-3
7	11	3040-00-919-5049	80063	SMD555536-4
7	12		80063	SM-B-165483-2
7	13		80063	SM-B-165483-1
8	1	5320-00-117-6853	96906	MS20470AD6-8
8	2	5340-01-114-2139	19220	AL3-575709
8	3	5320-00-957-3582	07707	AD42S
8	4	5320-00-952-4162	07707	AD43S
8	5	5410-00-933-0845	13175	SMC165382
8	6	5320-00-177-6853	96906	MS20470AD6-8
8	7	5340-00-836-1938	98003	H945SS2RG
8	8		80063	SM-C-165383
8	9		96906	MS20426-AD6
8	10		80063	SM-B-165331
8	11		80063	SM-B-165399
8	12		80063	SM-B-165332
8	13	5320-00-117-7288	96906	MS20426AD6-8
8	14		80063	SM-B-165331
8	15		80063	SM-B-165399
8	16		80063	SM-B-165332-1
8	17		96906	MS35494-131
8	18	4510-00-933-9953	80063	SMB165452
9	1	9999-00-937-5248	80058	MK1079G
9	2		80063	SMB564670-3
9	3		80063	SM-B-564670-4
9	4		80063	SM-B-563756
9	5	4130-00-007-2526	80063	SM-C-450478
9	6		80063	SC-B-200133
9	7		80063	SM-B-165463
9	8	5310-01-344-6751	81337	SM-B-374181
10	1		80063	SM-B-162201
10	2	5310-00-050-6646	96906	MS17830-6C
10	3	5310-00-595-6057	96906	MS15795-815
10	4		80063	SM-D-162194
10	5	5306-00-655-6170	96906	MS35307-338
10	6	5310-00-974-6623	96906	MS35338-140
10	7	5310-00-802-4701	96906	MS15795-813
10	8	5305-00-702-4523	96906	MS35307-306
10	9	5305-00-984-7341	96906	MS35191-273
10	10		80063	SC-D-595499
10	11		80063	SC-D-595500
10	12		81337	SM-B-162196-1

CROSS-REFERENCE INDEXES

FIGURE AND ITEM NUMBER INDEX

FIG.	ITEM	STOCK NUMBER	CAGEC	PART NUMBER
10	13		80063	SM-C-555549

By Order of the Secretary of the Army:

Official:

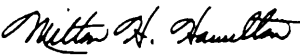
MILTON H. HAMILTON
*Administrative Assistant to the
Secretary of the Army*

05512

GORDON R. SULLIVAN
*General, United States Army
Chief of Staff*

DISTRIBUTION :

To be distributed in accordance with DA Form 12-25-E, block no. 6168, requirements for TM 10-5411-206-24P.

SOMETHING WRONG WITH THIS PUBLICATION?



THEN... JOT DOWN THE DOPE ABOUT IT ON THIS FORM. CAREFULLY TEAR IT OUT. FOLD IT AND DROP IT IN THE MAIL!

FROM (PRINT YOUR UNIT'S COMPLETE ADDRESS)
 CDR, 1st Br, 65th ADA
 ATTN: SP4 J. Brown
 Key West, FL 33040

DATE SENT
 10 Jun 79

PUBLICATION NUMBER
 TM 9-1430-550-34-1

PUBLICATION DATE
 7 Sep 72 .

PUBLICATION TITLE Unit of Radar Set
 AN/MPQ-50 Tested at the HFC

BE EXACT PIN-POINT WHERE IT IS

PAGE NO	PARA-GRAPH	FIGURE NO	TABLE NO
9-19		9-5	
21-2	step 1C	21-2	

IN THIS SPACE TELL WHAT IS WRONG AND WHAT SHOULD BE DONE ABOUT IT:

"B" Ready Relay K11 is shown with two #9 contacts. That contact which is wired to pin 8 of relay K16 should be changed to contact #10.

Reads: Multimeter B indicates 600 K ohms to 9000 K ohms.

Change to read: Multimeter B indicates 600 K ohms minimum.

Reason: Circuit being checked could measure infinity. Multimeter can read above 9000 K ohms and still be correct.

SAMPLE

PRINTED NAME GRADE OR TITLE AND TELEPHONE NUMBER

SP4 J.T. Brown, Jr.

SIGN HERE

SP4 James Brown, Jr.

TEAR ALONG PERFORATED LINE

RECOMMENDED CHANGES TO EQUIPMENT TECHNICAL PUBLICATIONS



THEN JOT DOWN THE DOPE ABOUT IT ON THIS FORM. CAREFULLY TEAR IT OUT FOLD IT AND DROP IT IN THE MAIL.

SOMETHING WRONG WITH THIS PUBLICATION?

FROM (PRINT YOUR UNIT'S COMPLETE ADDRESS)

DATE SENT

PUBLICATION NUMBER
TM 10-5411-206-24P

PUBLICATION DATE
30 SEP 93

PUBLICATION TITLE
SHELTER, ELECTRICAL EQUIPMENT

BE EXACT PIN-POINT WHERE IT IS

PAGE NO	PARA. GRAPH	FIGURE NO	TABLE NO

IN THIS SPACE TELL WHAT IS WRONG AND WHAT SHOULD BE DONE ABOUT IT:

PRINTED NAME GRADE OR TITLE AND TELEPHONE NUMBER

SIGN HERE

THIS EDITION OBSOLETE

DA FORM 2028-2 JUL 79

PREVIOUS EDITIONS ARE OBSOLETE

PS IF YOUR OUTFIT WANTS TO KNOW ABOUT YOUR RECOMMENDATION MAKE A CARBON COPY OF THIS AND GIVE IT TO YOUR HEADQUARTERS

1 Nov 80

FILL IN YOUR
UNITS ADDRESS



FOLD BACK

DEPARTMENT OF THE ARMY

OFFICIAL BUSINESS

COMMANDER
U.S. ARMY AVIATION AND TROOP COMMAND
ATTN: AMSAT-I-MP
4300 GOODFELLOW BOULEVARD
ST. LOUIS, MO 63120-1798

TEAR ALONG PERFORATED LINE

The Metric System and Equivalents

Linear Measure

1 centimeter = 10 millimeters = .39 inch
 1 decimeter = 10 centimeters = 3.94 inches
 1 meter = 10 decimeters = 39.37 inches
 1 dekameter = 10 meters = 32.8 feet
 1 hectometer = 10 dekameters = 328.08 feet
 1 kilometer = 10 hectometers = 3,280.8 feet

Weights

1 centigram = 10 milligrams = .15 grain
 1 decigram = 10 centigrams = 1.54 grains
 1 gram = 10 decigram = .035 ounce
 1 dekagram = 10 grams = .35 ounce
 1 hectogram = 10 dekagrams = 3.52 ounces
 1 kilogram = 10 hectograms = 2.2 pounds
 1 quintal = 100 kilograms = 220.46 pounds
 1 metric ton = 10 quintals = 1.1 short tons

Liquid Measure

1 centiliter = 10 milliliters = .34 fl. ounce
 1 deciliter = 10 centiliters = 3.38 fl. ounces
 1 liter = 10 deciliters = 33.81 fl. ounces
 1 dekaliter = 10 liters = 2.64 gallons
 1 hectoliter = 10 dekaliters = 26.42 gallons
 1 kiloliter = 10 hectoliters = 264.18 gallons

Square Measure

1 sq. centimeter = 100 sq. millimeters = .155 sq. inch
 1 sq. decimeter = 100 sq. centimeters = 15.5 sq. inches
 1 sq. meter (centare) = 100 sq. decimeters = 10.76 sq. feet
 1 sq. dekameter (are) = 100 sq. meters = 1,076.4 sq. feet
 1 sq. hectometer (hectare) = 100 sq. dekameters = 2.47 acres
 1 sq. kilometer = 100 sq. hectometers = .386 sq. mile

Cubic Measure

1 cu. centimeter = 1000 cu. millimeters = .06 cu. inch
 1 cu. decimeter = 1000 cu. centimeters = 61.02 cu. inches
 1 cu. meter = 1000 cu. decimeters = 35.31 cu. feet

Approximate Conversion Factors

To change	To	Multiply by	To change	To	Multiply by
inches	centimeters	2.540	ounce-inches	newton-meters	.007062
feet	meters	.305	centimeters	inches	.394
yards	meters	.914	meters	feet	3.280
miles	kilometers	1.609	meters	yards	1.094
square inches	square centimeters	6.451	kilometers	miles	.621
square feet	square meters	.093	square centimeters	square inches	.155
square yards	square meters	.836	square meters	square feet	10.764
square miles	square kilometers	2.590	square meters	square yards	1.196
acres	square hectometers	.405	square kilometers	square miles	.386
cubic feet	cubic meters	.028	square hectometers	acres	2.471
cubic yards	cubic meters	.765	cubic meters	cubic feet	35.315
fluid ounces	milliliters	29.573	cubic meters	cubic yards	1.308
pints	liters	.473	milliliters	fluid ounces	.034
quarts	liters	.946	liters	pints	2.113
gallons	liters	3.785	liters	quarts	1.057
ounces	grams	28.349	liters	gallons	.264
pounds	kilograms	.454	grams	ounces	.035
short tons	metric tons	.907	kilograms	pounds	2.205
pound-feet	newton-meters	1.356	metric tons	short tons	1.102
pound-inches	newton-meters	.11296			

Temperature (Exact)

°F Fahrenheit temperature 5/9 (after subtracting 32) Celsius temperature °C

